

Serie **RN 3000**  
**RN 4000**  
**RN 6000**

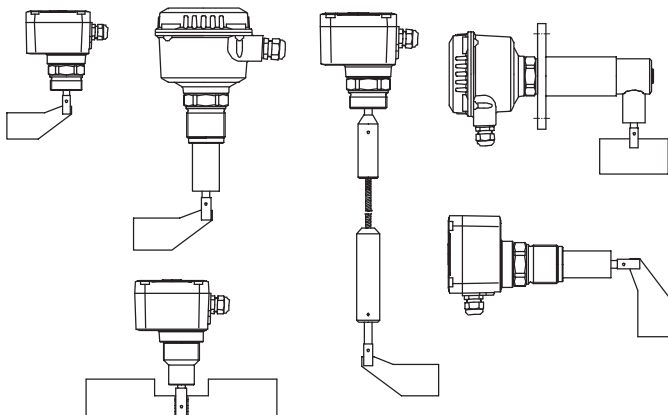

Betjeningsvejledning

UWT GmbH

Westendstraße 5  
D-87488 Betzigau

Tel.: +49 (0)831 57123-0

Fax: +49 (0)831 76879

Internet: [www.uwtgroup.com](http://www.uwtgroup.com)

E-Mail: [info@uwtgroup.com](mailto:info@uwtgroup.com)

Denne betjenings- vejledning gælder for:	Typer	RN 3001 / 3002 / 3003 / 3004 / 3005 RN 4001 RN 6001 / 6002 / 6003 / 6004
	Godkendelse	CE /TR-CU ATEX 1/2D / IEC-Ex t IIIC

# Indholdsfortegnelse

---

Sikkerhedshenvisninger/advarsler	Side	4
Anvendelsesområde	Side	4
Tekniske data	Side	5
Anvendelse	Side	19
Montering	Side	26
Elektrisk tilslutning	Side	29
Koblingslogik	Side	34
Indstilling	Side	38
Vedligeholdelse	Side	38
ATEX / IEC-Ex - henvisninger	Side	39

## Sikkerhedshenvisninger / advarsler

---

Installation, vedligeholdelse og ibrugtagning må udelukkende udføres af kvalificerede fagfolk.

I forbindelse med den elektriske tilslutning skal de lokale bestemmelser eller VDE 0100 overholdes.

Apparatet må udelukkende åbnes i spændingsfri tilstand.

Alle forbindelseskabler skal være isoleret til mindst 250 V AC driftsspænding. Temperaturbestandigheden skal være mindst 90°C (194°F).

Sikkerheden kan ikke garanteres ved uhensigtsmæssig anvendelse af apparatet..

## Anvendelsesområde

---

Niveau-stopkontakt til niveaumåling af styrtgods.

Kan anvendes som fulddetektor, behovsdetektor og tom-detektor.

## Tekniske data

### Kabinet

#### RN 3000

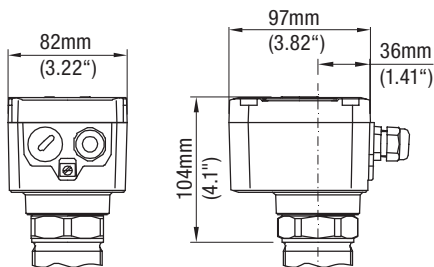

#### RN 4000

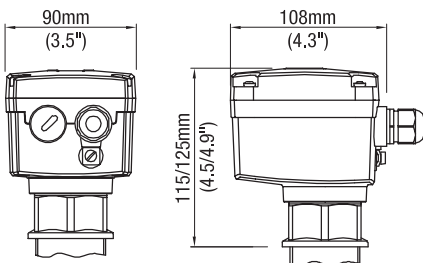

#### RN 6000

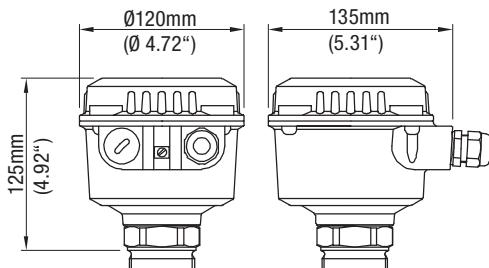

## Temperaturmellestykke

RN 3001  
RN 3002  
RN 3004

RN 6001  
RN 6002  
RN 6004

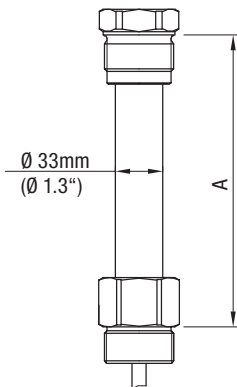

Mål A	A = 0mm (0")	A = 200mm (7.87")	A = 300mm (11.8")	A = 400mm (15.7")
	80°C (176°F)	150/250°C (302/482°F)	350°C (662°F)	600°C (1112°F)

RN 3003

RN 6003

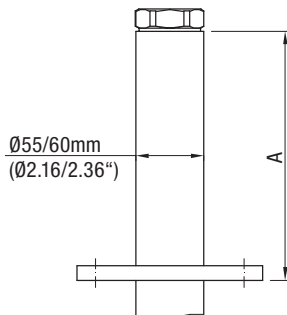

Mål A	A = 10mm (0.39")	A = 75mm (2.95")	A = 210mm (8.26")
	80°C (176°F)	80°C (176°F)	150/250°C (302/482°F)
	0,8bar (11.6psi)	5/10bar (73/145psi)	0,8/5/10bar (11.6/73/145psi)

RN 3001  
RN 4001  
RN 6001

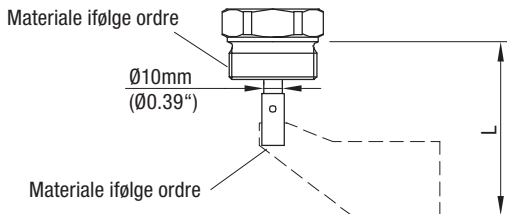

L = 70mm ... 1500mm (2.75" ... 59")

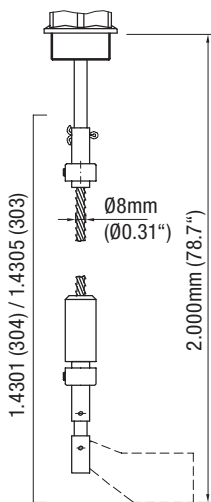

Kabelforlængelse

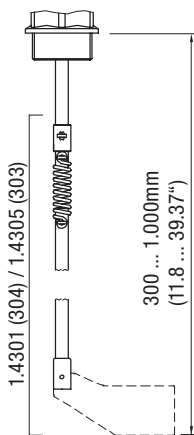

Pendulaksel



RN 3002

RN 6002

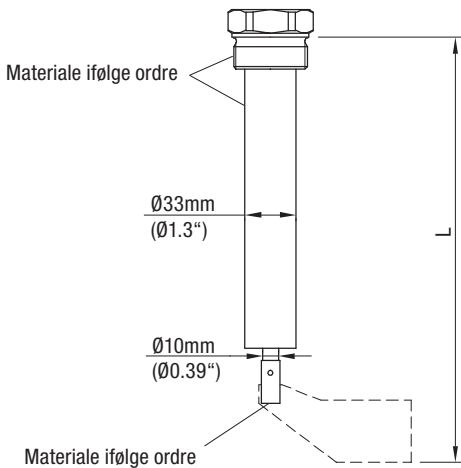

L = 250mm ... 4000mm (9.84" ... 158")

RN 3002-Rope  
RN 6002-Rope

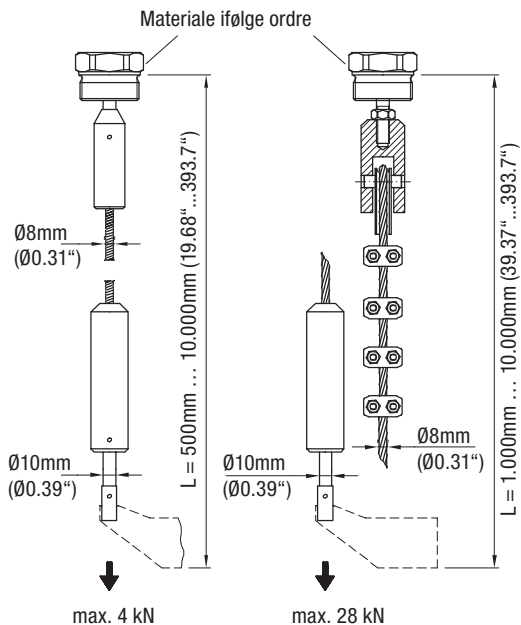

**RN 3003**  
**RN 6003**

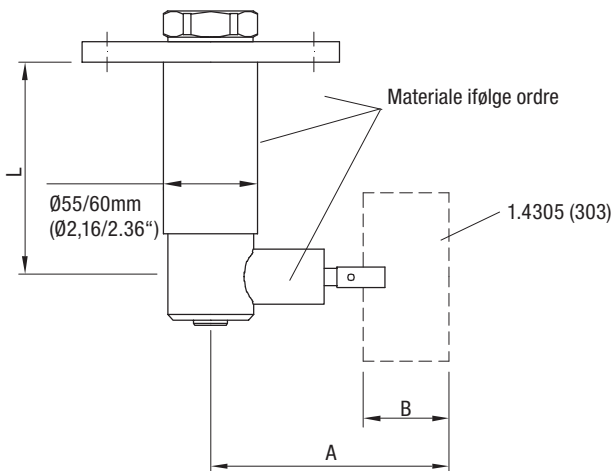

L = 125mm ... 300mm (4.92" ... 11.81")

A	B
139mm (5.47")	50mm (1.97")
187mm (7.28")	98mm (3.9")

**RN 3004  
RN 6004**

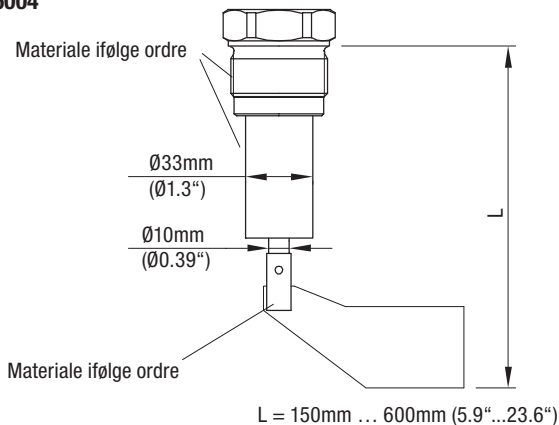

**RN 3005**

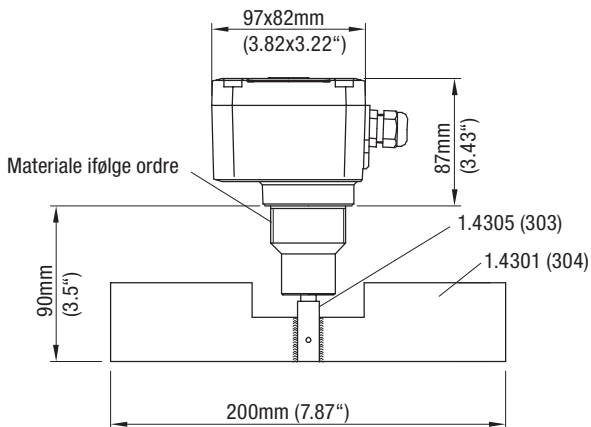

## Firkantet vinge

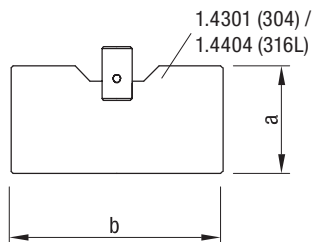

A	B
50mm (1.97")	98mm (3.86")
50mm (1.97")	150mm (5.9")
50mm (1.97")	250mm (9.84")
98mm (3.86")	98mm (3.86")
98mm (3.86")	150mm (5.9")
98mm (3.86")	250mm (9.84")

## Udkoblet

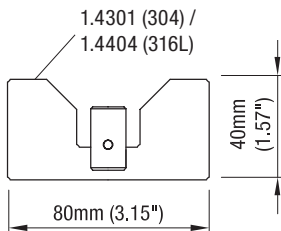

Muffevinge

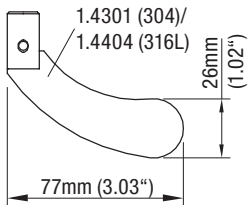
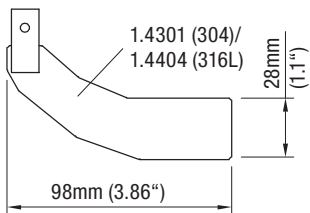
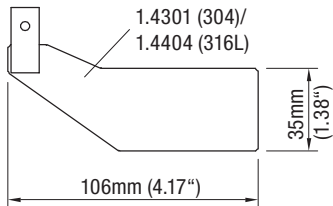
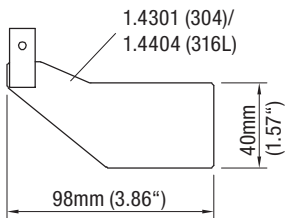

Klapvinge dobbeltsidet

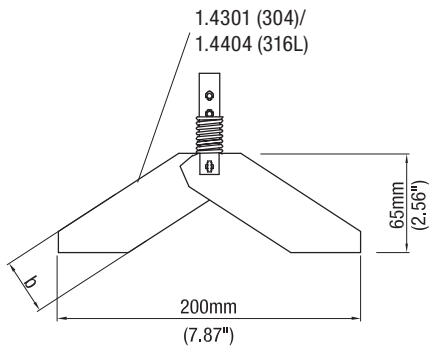

Klapvinge ensidet

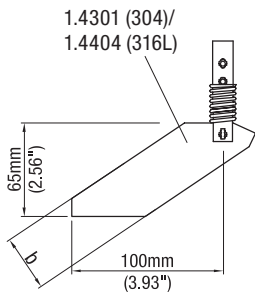

b=28mm (1.1") / 37mm (1.46")

## Gummivinge

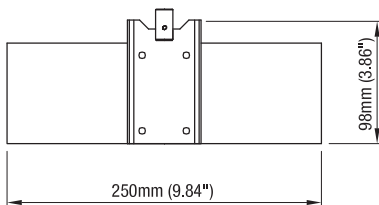

---

## Universalvinge

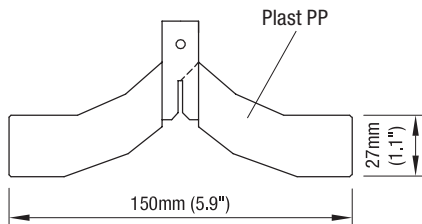





°C

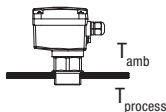

## RN 3000

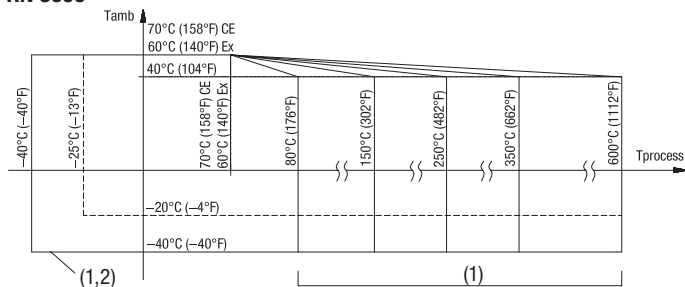

## RN 4000

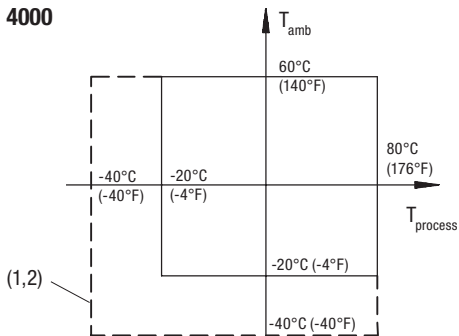

- (1) Se typeskilt  
(2) med kabinetvarmer

## RN 6000

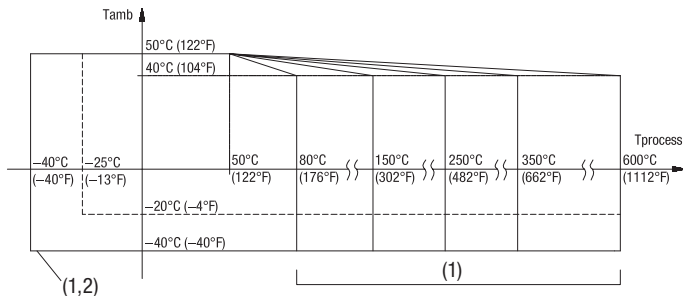

- (1) Se typeskilt
- (2) med kabinetvarmer



### RN 3000 / RN 6000

min.  $-0,9\text{bar}$  ( $-13,1\text{psi}$ )  
(1) max.  $0,8 / 5 / 10\text{bar}$  ( $11,6 / 73 / 145\text{psi}$ )

### RN 4000

min.  $-0,9\text{bar}$  ( $-13,1\text{psi}$ )  
max.  $0,8\text{bar}$  ( $11,6\text{psi}$ )

- (1) Se typeskilt

## Anvendelse

RN 3001

RN 4001

RN 6001

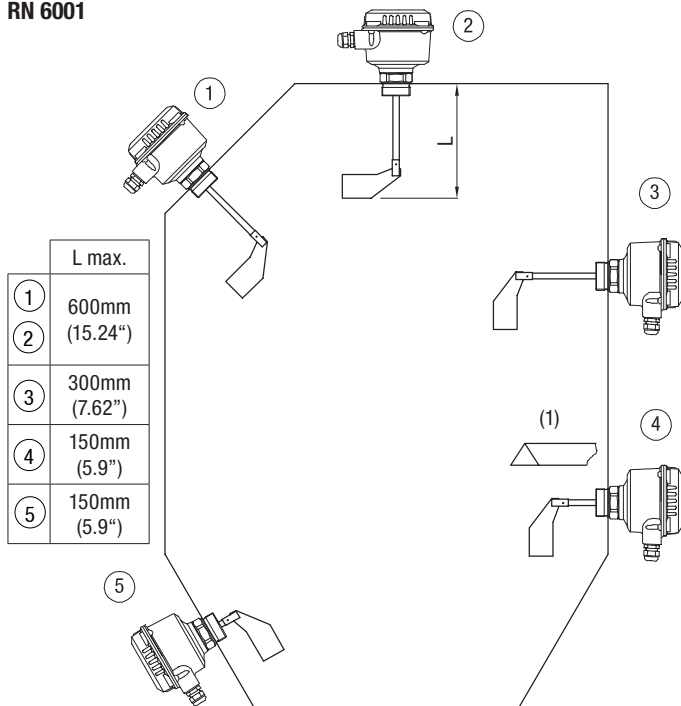

(1) Stålvinkel ved høje mekaniske kræfter

RN 3001  
RN 4001  
RN 6001

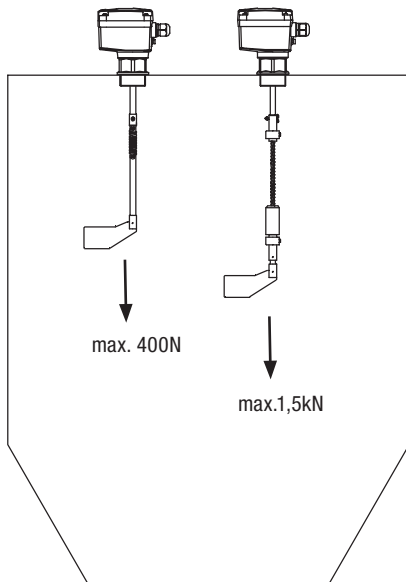

Pendulaksel

Kabelforlængelse

**RN 3002**  
**RN 6002**

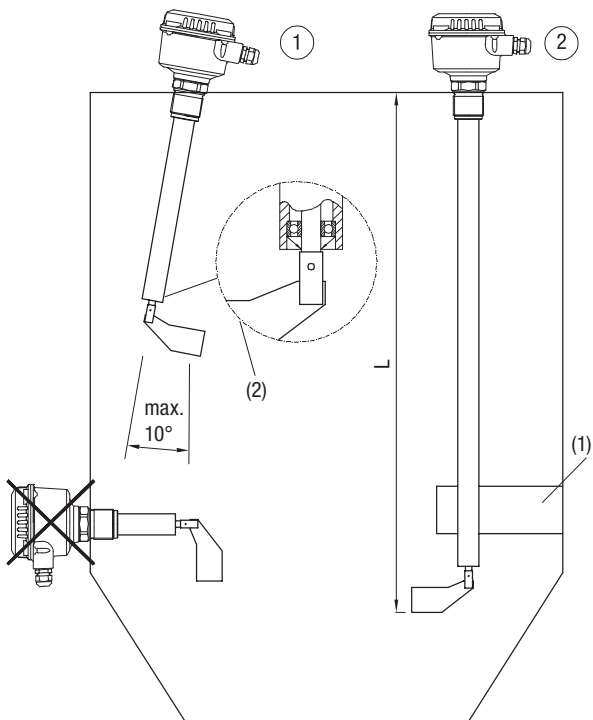

	L max.
①	3.000mm (118.1")
②	4000mm (158")

- (1) Afstivning  
 (2) Skrå montering med option pos. 32-leje ved rørende

**RN 3002-Kabel**

**RN 6002-Kabel**

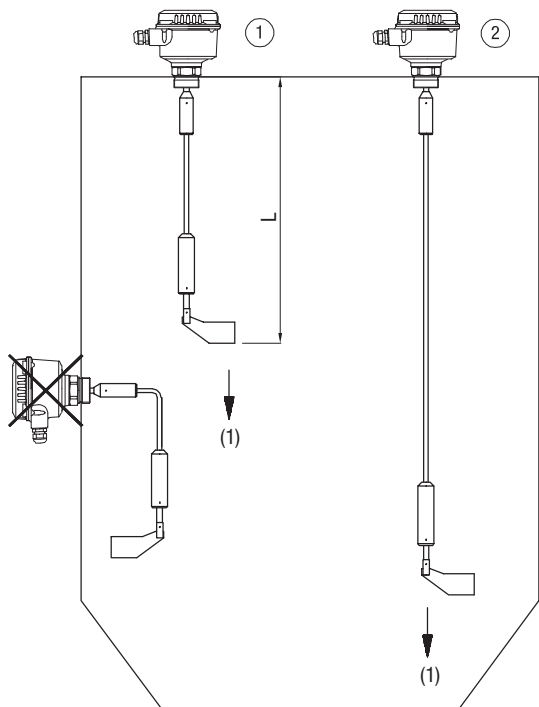

	L
①	min. 500mm (19.68")
②	max. 10.000mm (394")

(1) Maks. trækraft 4kN / 28kN, se typeskilt

**RN 3003**  
**RN 6003**

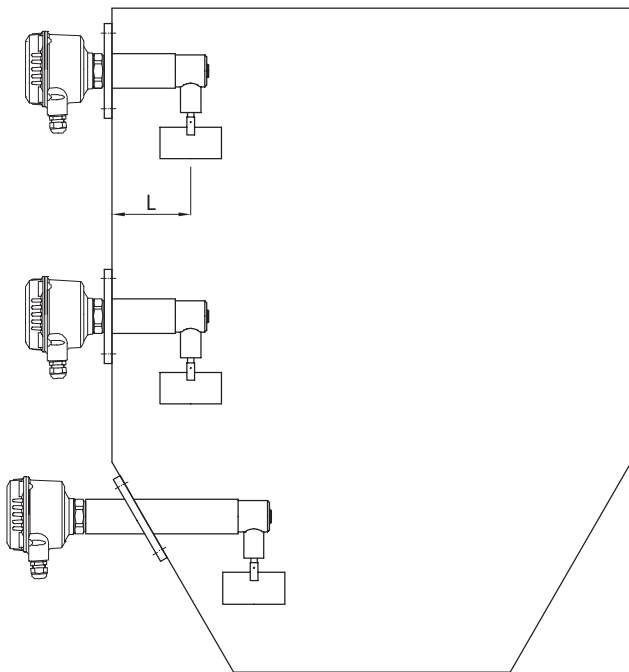

L max.
300mm (11.81")

**RN 3004**  
**RN 6004**

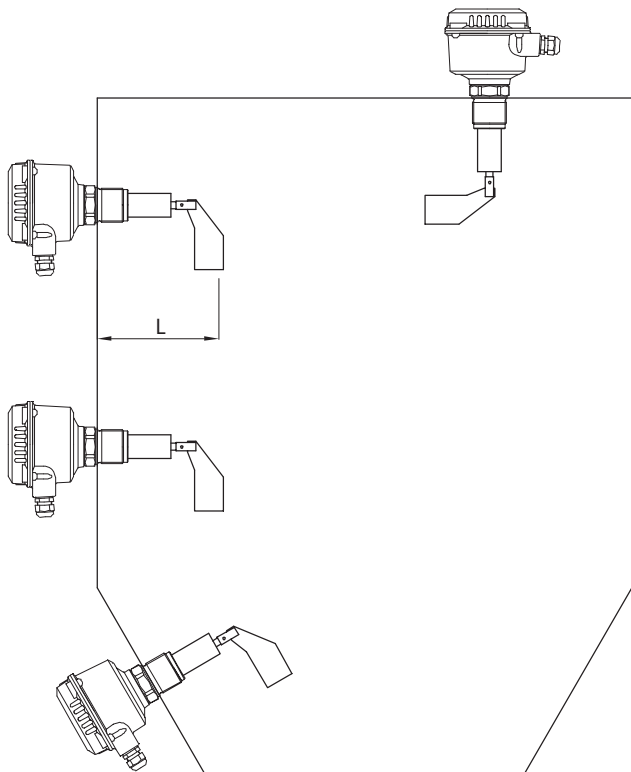

L max.

300mm (11.81")



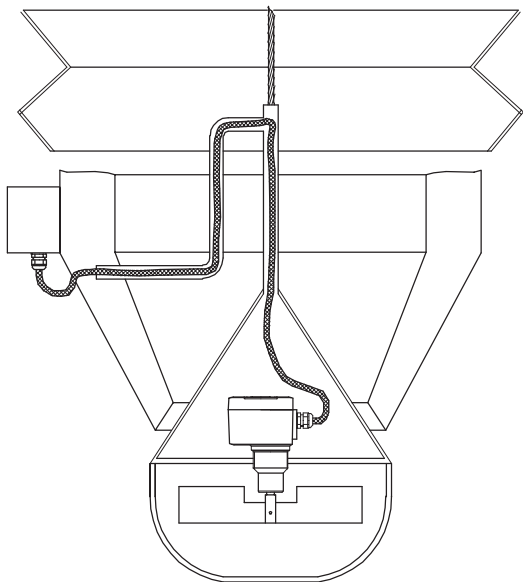

Ladeteleskop

## Montering

### Eksempel: Indføring af klapvingen i lange monteringsstudser

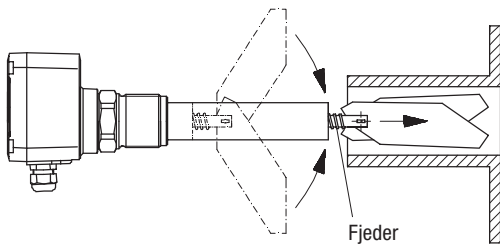

### Fastgørelse/tætning

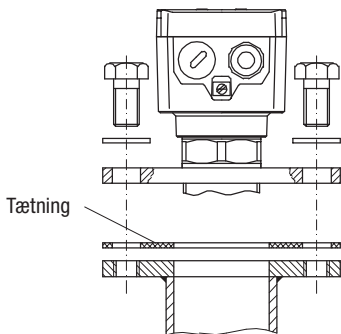
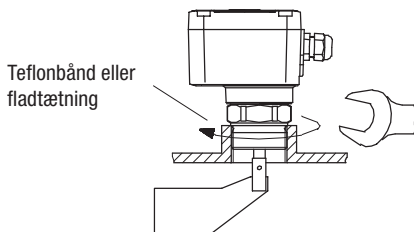

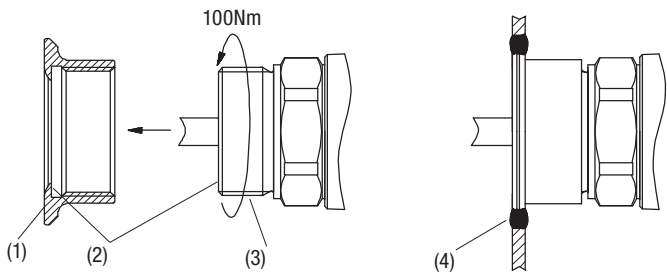

- (1) Certificeret påsvejsningsmuffe obligatorisk
- (2) Metal-metalag uden afstand
- (3) Teflonbånd
- (4) Sammensvejsning (se hygiejneforskrifterne)

## Positionering

Beskyttelsesmåde  
IP 66

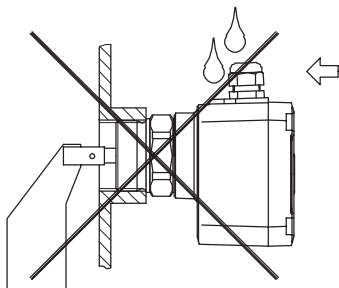
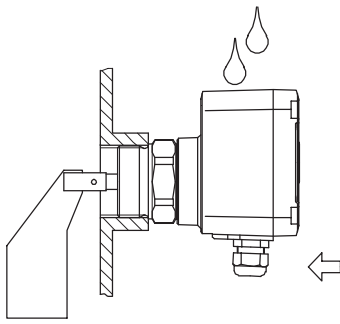

Option: Kappe til beskyttelse mod vejrforhold

til Ex kun tilladt til zone 22

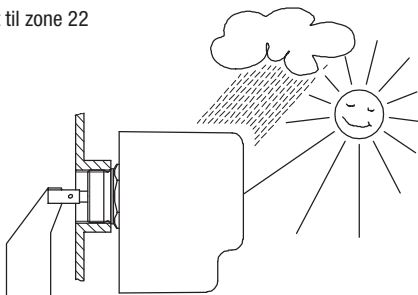

## Elektrisk tilslutning

---

**RN 3000**

**RN 4000**

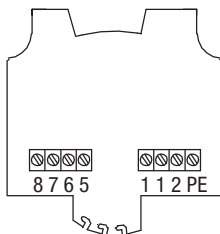

**RN 6000**

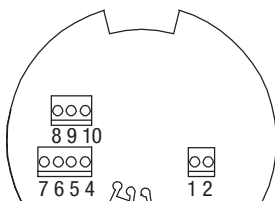

Forbindelsesklemmer alt efter model

Version

- AC
- DC
- AC/DC

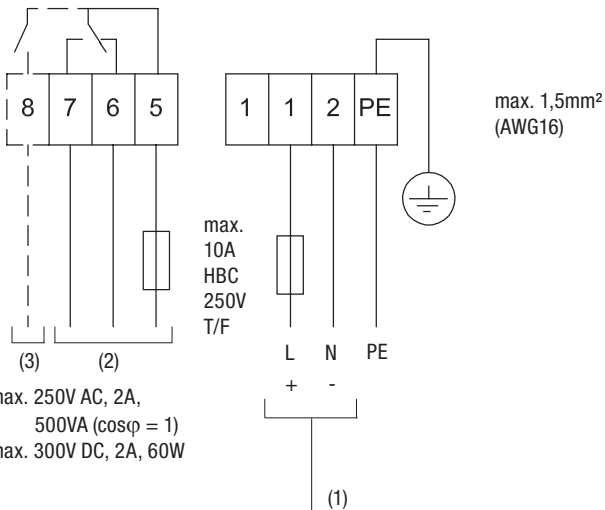

Version <sup>(4)</sup>

AC	24/48/115/230V ±10% <sup>(5)</sup> , 50/60Hz max. 4VA
DC	24V DC ±15% <sup>(5)</sup> , max. 2,5W
AC/DC	24V DC ±15% <sup>(5)</sup> , max. 4W 22...230V ±10% <sup>(5)</sup> , 50/60Hz, max. 10VA

- (1) Forsyning
- (2) Signaludgang
- (3) Alarmudgang
- (4) se typeskilt
- (5) inklusive 10 % fra EN 61010

**Version**  
**- PNP**

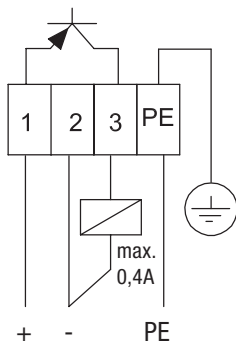

24V DC  $\pm 15\%$  <sup>(1)</sup>  
max. 0,6A

(1) inklusive 10 % fra EN 61010

Version

- AC
- DC

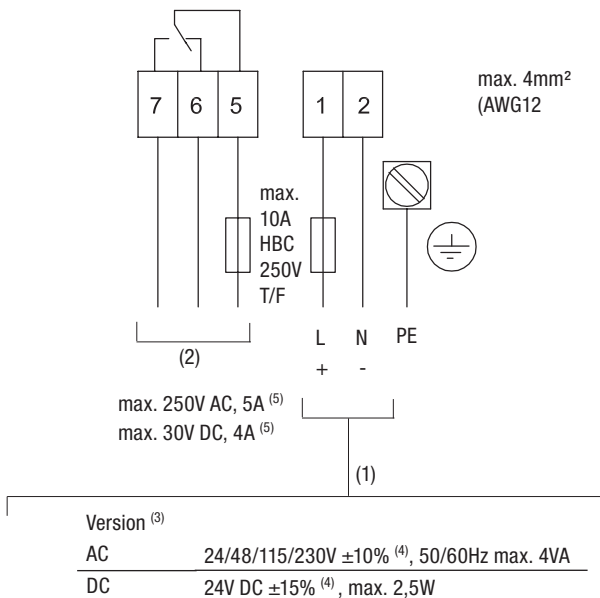

- (1) Forsyning
- (2) Signaludgang
- (3) Alarmudgang
- (4) se typeskilt
- (5) inklusive 10 % fra EN 61010



Version  
- AC/DC

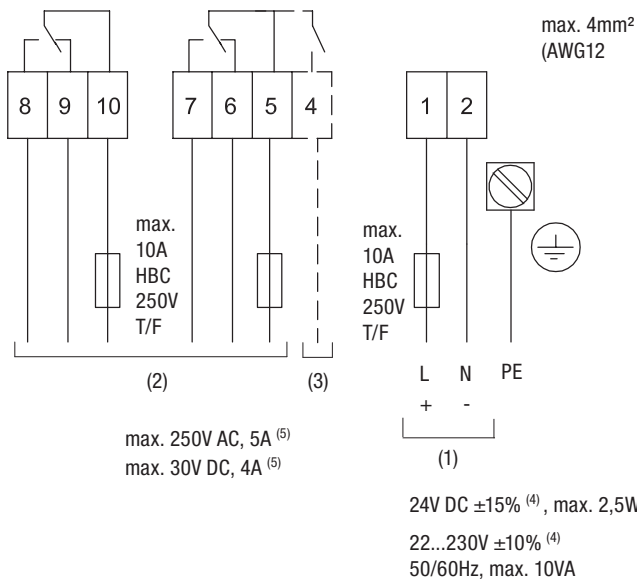

- (1) Forsyning
- (2) Signaludgang
- (3) Alarmudgang
- (4) se typeskilt
- (5) inklusive 10 % fra EN 61010

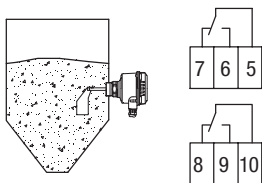
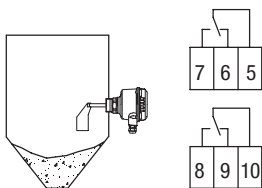

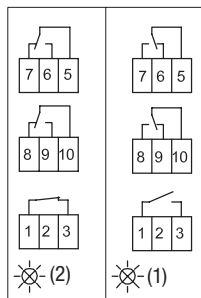
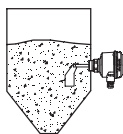
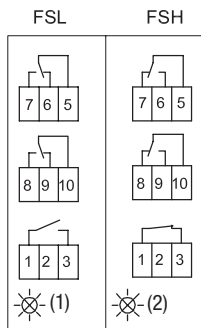
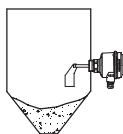

RN 3000/4000:

FSL FSH

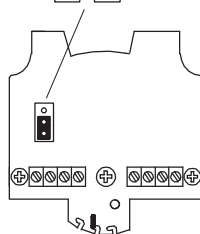

RN 6000:

FSL

FSH

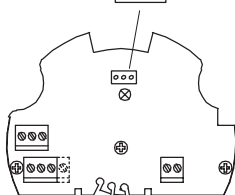

- (1) gul
- (2) grøn

## Signaludgang forsinkelse

**RN 3000**

**RN 4000**

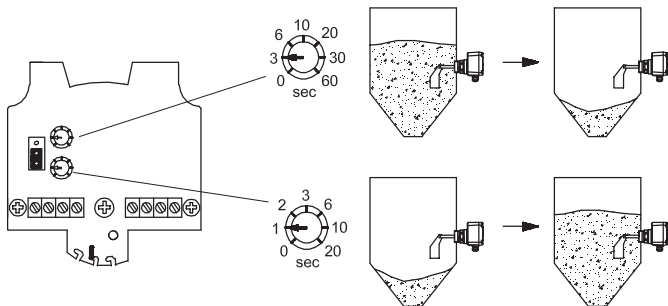

**RN 6000**

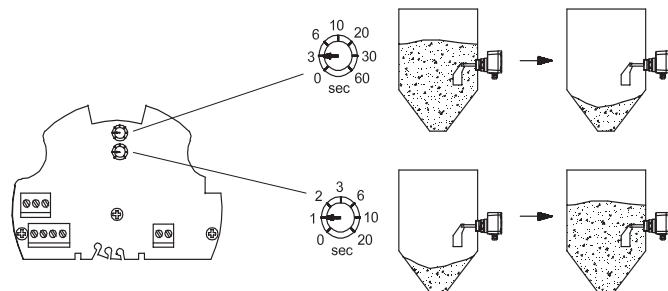

## Alarmudgang

### Model med forløbskontrol

Ingen fejl

RN 3000/4000:

RN 6000:

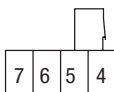
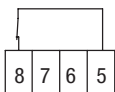

Fejl

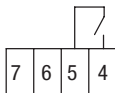
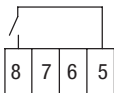

# Indstilling

## Indstilling af fjederkraften

RN 3000  
RN 4000

RN 6000

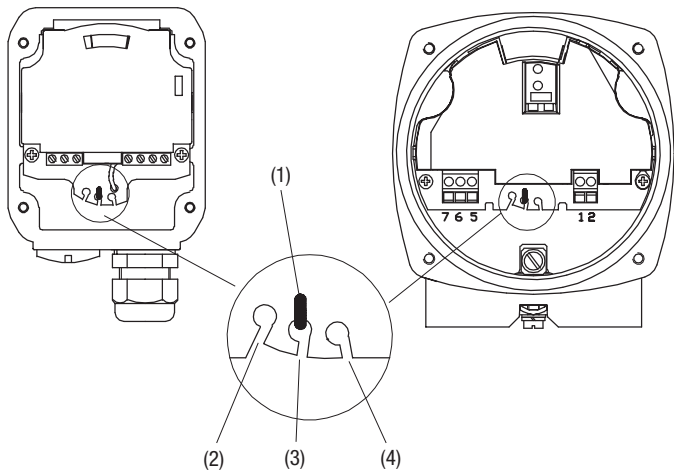

- (1) Fjeder
- (2) let: lette fyldstoffer
- (3) mellem: universal
- (4) tung: fyldstoffer, der nemt brænder på

## Vedligeholdelse

Almindeligvis ikke påkrævet

# ATEX II 1/2D + IEC-Ex t IIIC Da/Db

## Henvisninger

### Tilladt relativtryk

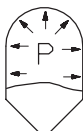

-0,2...+0,1bar  
(-2.9...+1.45psi)

### Zonegrænser

**RN 3000**  
**RN 4000**

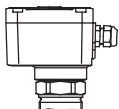

**RN 6000**

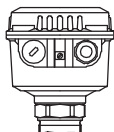

- (1) **2D**
- (2) **Db**
- (3) **21**

- (1) **1D**
- (2) **Da**
- (3) **20**

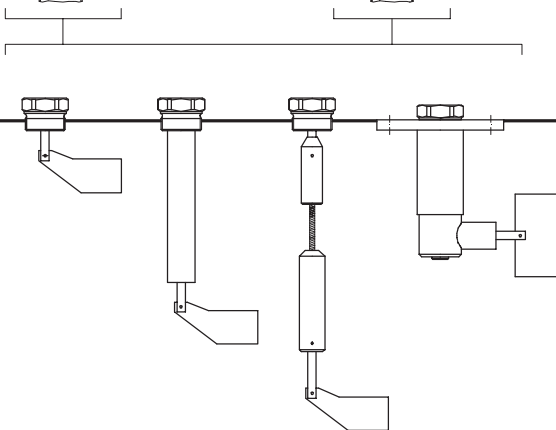

(1) Kategori ATEX

(2) EPL (IEC-Ex)

(3) Zone

## Omgivende temperatur

## maks. overfladetemperatur



Zone 21	Zone 20		
30°C (86°F)	50°C (122°F)	90°C (194°F) 120°C (248°F) <sup>(1)</sup>	
40°C (104°F)	60°C (140°F)	100°C (212°F) 120°C (248°F) <sup>(1)</sup>	
50°C (122°F)	70°C (158°F)	110°C (230°F) 120°C (248°F) <sup>(1)</sup>	
50°C (122°F)/ 60°C (140°F)	80°C (176°F)	120°C (248°F)	
50°C (122°F)/ 60°C (140°F)	90°C (194°F)	120°C (248°F)	
	100°C (212°F)	120°C (248°F)	
	110°C (230°F)	120°C (248°F)	
	120°C (248°F)	120°C (248°F)	
	130°C (266°F)	130°C (266°F)	
	140°C (284°F)	140°C (284°F)	
	150°C (302°F)	150°C (302°F)	
	160°C (320°F)	160°C (320°F)	
	170°C (338°F)	170°C (338°F)	
	180°C (356°F)	180°C (356°F)	
	190°C (374°F)	190°C (374°F)	
	200°C (392°F)	200°C (392°F)	
	210°C (410°F)	210°C (410°F)	
	220°C (428°F)	220°C (428°F)	
230°C (446°F)	230°C (446°F)		
240°C (464°F)	240°C (464°F)		
250°C (482°F)	250°C (482°F)		

(1) Ved anvendelse af elektronikken "AC/DC".



**RN 3000  
RN 4000**

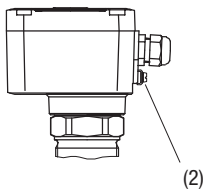
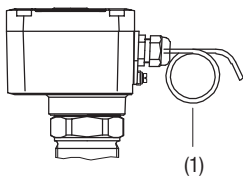

**RN 6000**

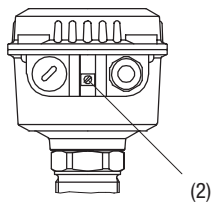
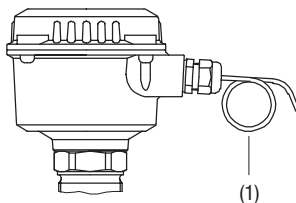

- (1) Mek. aflastning skal sikres
- (2) Tilsluttes til potentialudligning

## ATEX / IEC-Ex: Yderligere henvisninger

Ved montering og tilslutning skal de pågældende forskrifter i opførelseslandet overholdes.

Ibrugtagning kun ved lukket apparat.

Apparatet må udelukkende åbnes i spændingsfri tilstand.

Inden åbning af apparatet skal det sikres, at der ikke er nogen støvaflejring, og at der ikke hvirvler støv op.

Monteringen skal udføres, således at der ikke kan dannes gnister mellem aluminiumskabinettet og stål, når man støder mod eller stryger hen over apparatet.

Ved procestemperaturer over 230°C skal de leverede flangetætninger og glidemuffens pakninger jævnligt kontrolleres for deres korrekte tilstand.

Kabelforskrninger:

Udførelsen skal ske i henhold til installationslandets retningslinjer.

Ubenyttede kabelindgange skal lukkes ved hjælp af blindpropper, der er godkendt til dette formål.

Om muligt skal producentens leverede dele anvendes.

Der skal sikres en aflastning for de kabelforskrninger, producenten har leveret. Forbindelseskablernes diameter skal passe til kabelforskrningernes klemområde.

Hvis der anvendes andre dele end de dele, producenten har leveret, skal nedenstående sikres:

Delene skal have en godkendelse, der passer til niveaudetektorens godkendelse (certifikat og beskyttelsesmåde).

Den tilladte driftstemperatur skal være i overensstemmelse med den minimale omgivende temperatur for niveaudetektoren samt den maksimale omgivende temperatur for niveaudetektoren, som er øget med 10 K.

Delene skal monteres i henhold til producentens manual.