

Table of contents

	Page
Safety notes/ Technical support	2

Introduction	3

Function	4

Technical data	6

Approvals	14

Options	15

Mounting	16

Electrical installation	20

Signal and alarm output	25

Setting/ Sensitivity	28

Maintenance	29

Notes for use in Hazardous Locations	30

Disposal	32

Subject to technical change
All dimensions in mm (inches).

We assume no liability for typing errors.
Different variations than specified are possible.
Please contact our technical consultants.

Safety notes / Technical support

Notes

- Installation, maintenance and commissioning may be accomplished only by qualified technical personnel.
- The product must be used only in the manner outlined in this instruction manual.

Special attention must be paid to warnings and notes as follows:

WARNING



Relates to a caution symbol on the product: A failure to observe the necessary precautions can result in death, serious injury and/or considerable material damage.

WARNING



Relates to a caution symbol on the product: Risk of electric shock

WARNING



A failure to observe the necessary precautions can result in death, serious injury and/ or considerable material damage.

This symbol is used, when there is no corresponding caution symbol on the product.

CAUTION

A failure to observe the necessary precautions can result in considerable material damage.

Safety symbols

In manual and on product	Description
	CAUTION: refer to accompanying documents (manual) for details.
	Earth (ground) Terminal
	Protective Conductor Terminal

Technical support

Please contact your local supplier (for address see www.uwtgroup.com). Otherwise you can contact:

UWT GmbH
 Westendstr. 5
 D-87488 Betzigau

Tel.: 0049 (0)831 57123-0
 Fax: 0049 (0)831 76879
info@uwtgroup.com
www.uwtgroup.com

Introduction

Applications

The ROTONIVO is an electromechanical Level limit switch and is used for level monitoring of bulk goods.

The units can be delivered with a wide range of Ex-approvals for use in Hazardous Areas.

They can be equipped for process over- and lowpressure and also for very high or low process temperatures.

Selected applications:

- **building materials industry**
lime, styrofoam, moulding sand, etc.
- **food industry**
milk powder, flour, salt, etc.
- **plastics industry**
plastics granules etc.
- **timber industry**
- **chemical industry**
- **mechanical engineering**

The ROTONIVO is normally screwed into the lateral container wall so that it is in level with the filling height to be registered and monitored.

The device can also be mounted from the top of the container. In this case an extension piece is used to mount the probe level with the height to be registered.

The length of the probe can be up to 4 m (158") with an extension tube or up to 10 m (394") with an extension rope.

The use of a sliding sleeve for the version RN 3002/ RN 6002 is recommended so that the switch point can be changed easily during operation of the device.

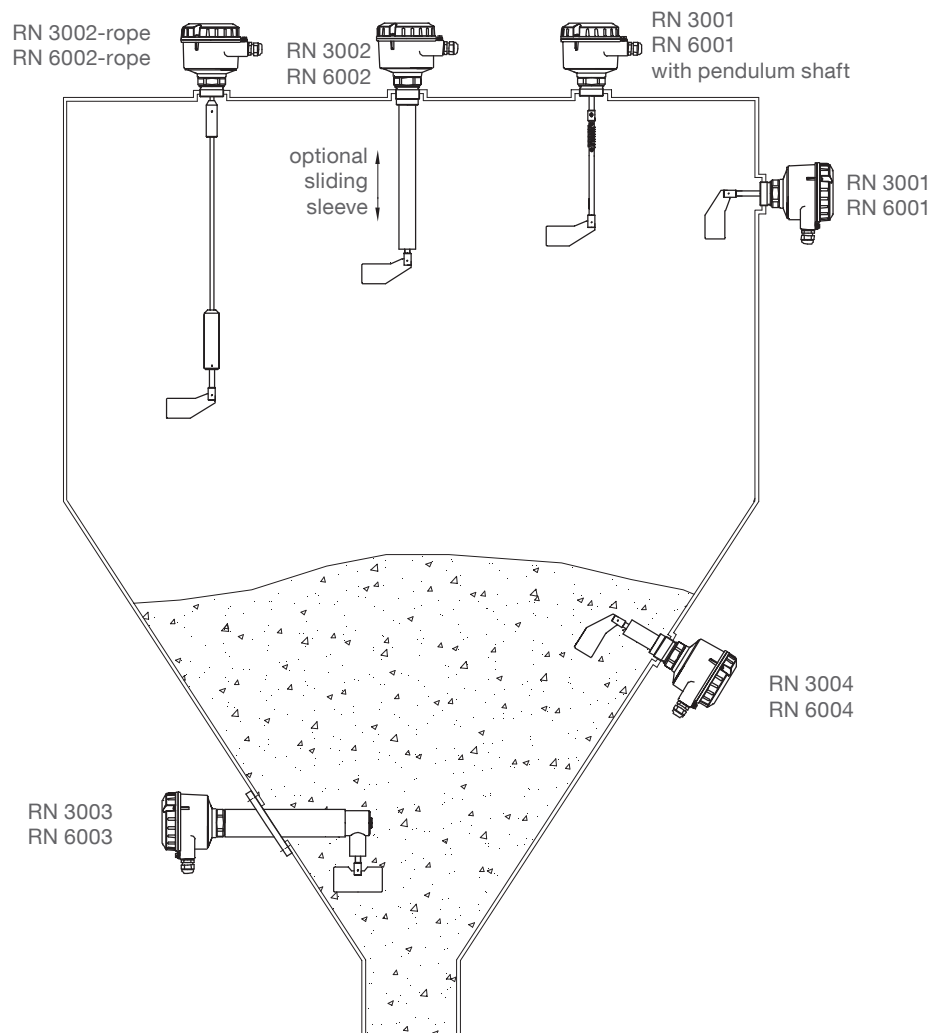

Function

A measuring vane is driven by a synchronous motor. The bearing of the motor inside the housing allows it to swing. The motor is fixed to a switching lug.

If the vane is uncovered, a spring pulls the motor and switching lug to the left position (figure 1).

When material covers the vane and thus stops the rotation, the motor and switching lug swings to the right position (figure 2). The signal output indicates "covered" and the motor is stopped.

When the vane becomes uncovered due to falling material, the spring pulls the motor and switching lug back to the left position (figure 1). The motor is started and the signal output indicates "uncovered".

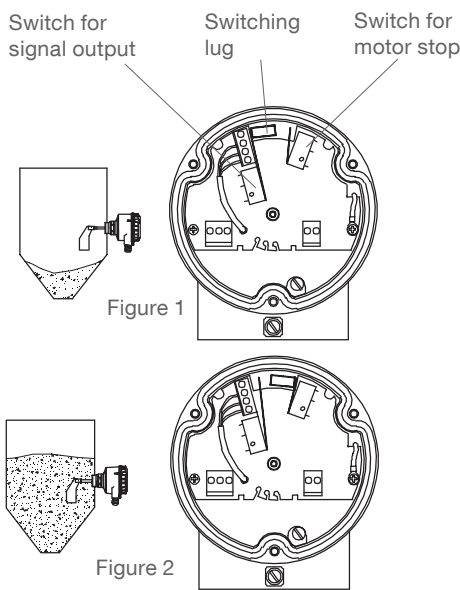

Fail safe alarm

With the option fail safe alarm it is possible to recognize a fault of the unit in time and to initiate an alarm relay. The following faults are observed:

- Motor
- Gear
- Electronic for motor power supply
- Supply voltage failure
- Defect of the connecting wires

Functional safety SIL2 (IEC 61508)

With option Functional safety the unit observes the motor, gear and electronic. The result of this diagnostics is present on the signal output, which states the full/ empty condition.

Switchable signal output (Fail safe high/ low)

With version "Universal voltage", "PNP" and optional "AC" a switchable signal output FSH/ FSL is integrated.

Signal output delay:

The version "Universal voltage" and "PNP" has an integrated adjustable delay for the signal output.

Selection guide

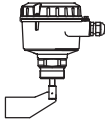
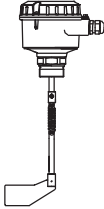
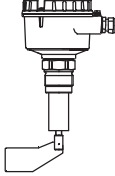
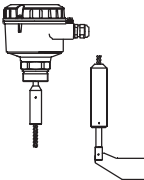
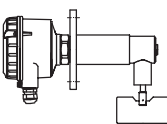
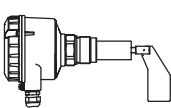
	RN 3001 RN 6001	RN 3001 RN 6001 pendulum shaft	RN 3002 RN 6002	RN 3002-ropes RN 6002-ropes	RN 3003 RN 6003	RN 3004 RN 6004
						
Full detector	x	x*	x	x	x	x
Demand detector	x			x*	x	x
Empty detector	x			x*	x	x
Vertical mounting	x	x	x	x*		x
Oblique from the top	x		x**			x
Horizontal mounting	x				x	x
Oblique from the bottom	x					x

* consider max. permitted mech. traction force

** only with option "bearing at tube end"

Function

Shaft sealing and metal material

Application	Material of Radial rotary shaft sealing ⁽¹⁾			Metal		Bearing
	NBR (Nitrile Butadiene Rubber)	FPM	PTFE	Aluminium	Stainless steel ⁽²⁾ 1.4301/ SS 304	Stainless steel
Animal feed press			x		x	x
Synthetic granules, powders	x			x		
Salt			x		x	x
Dust filter (temp. up to 392°F)			x		x	
Dust filter (temp. up to 302°F)		x			x	
Bitumen			x		x	
Cement	x			x		
Wood chip dryer			x		x	
Pressure conveying vessel, 8 bar			x		x	
Sugar	x			x		
Flour	x			x		
Carbon black	x			x		

⁽¹⁾ Shaft sealings are available as well food grade conform and metal detectable (see options pos.17 and 29y). According to selected process temperature and process pressure they are delivered consisting of the following materials:

NBR	max. 80°C and max. 0.8 bar
FPM	max. 150°C and max. 0.8 bar
PTFE	max. 250°C and max. 0.8 bar
PTFE	max. 80°C/ 150°C/ 250°C and max. 5 bar/ 10 bar

⁽²⁾ In particular cases 1.4404 (SS316L) is recommended

Electronic

RN 3000								
Power supply		Output signal						
		SPDT ⁽¹⁾	DPDT	PNP	FSH/ FSL ⁽²⁾	Adjustable delay	Fail safe alarm	
AC version	24 V or 48 V or 115 V or 230 V AC	•	-	-	-	-	-	-
DC version	24 V DC	•	-	-	-	-	-	-
DC version	24 V DC PNP	-	-	•	•	•	-	-
Universal voltage	24 V DC/ 22 .. 230 V AC	•	-	-	•	•	•	option
RN 6000								
Power supply		Output signal						
		SPST	SPDT ⁽¹⁾	DPDT	PNP	FSH/ FSL ⁽²⁾	Adjustable delay	Fail safe alarm
AC version	24 V or 48 V or 115 V or 230 V AC	-	•	-	-	-	-	-
DC version	24 V DC	-	•	-	-	-	-	-
Universal voltage	24 V DC/ 22 .. 230 V AC	-	-	• ⁽³⁾	-	•	•	option
Universal voltage SIL2	24 V DC/ 22 .. 230 V AC	•	• ⁽⁴⁾	-	-	•	•	-

⁽¹⁾ Microswitch, with Universal voltage Relais

⁽²⁾ Switchable signal output (Fail safe high/ low)

⁽³⁾ For Ex approval "Increased safety" (pos.2 C,R,S,4) not in combination with option Fail safe alarm

⁽⁴⁾ Additional output, not SIL conform

Technical Data

Dimensions

Housing versions

Series RN 3000
Standard

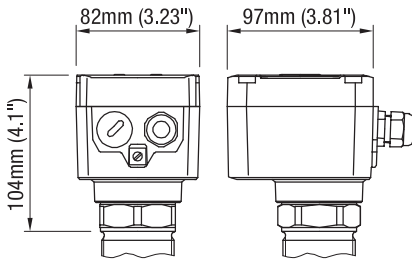

Series RN 6000
Standard

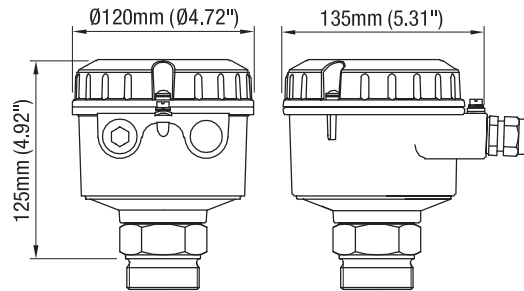

Series RN 6000
de explosionproof with increased
safety terminal box

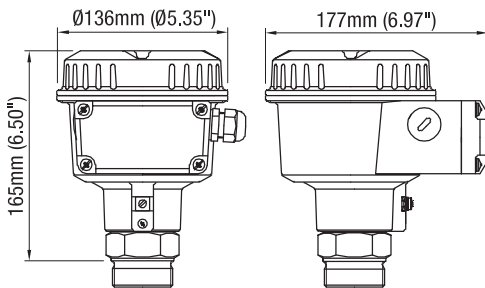

Series RN 6000
d flameproof/ explosionproof

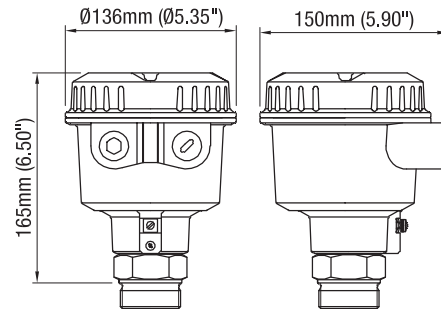

Extensions

RN ..001

Process temperature	A
150°C (302°F)	200mm (7.87")
250°C (482°F)	200mm (7.87")
350°C (662°F)	300mm (11.8")
600°C (1112°F)	400mm (15.7")
1.100°C (2012°F)	700mm (27.6")

Thread/ flange: L=70 .. 1.000mm (2.76 .. 39.4"), Ø10mm (0.39")

Temperature extended shaft: Ø33mm (Ø1.3"), A

Triclamp: L=70 .. 1.000mm (2.76 .. 39.4")

EHEDG ED class I: L=100 .. 1.000mm (3.94 .. 39.4"), 29mm (1.14"), Flush welding socket

With measuring vanes "boot shaped" and "hinged vane" the length "L" can be increased by 10mm (0.39"). Details see selection code pos.10.

Technical Data

RN ..002

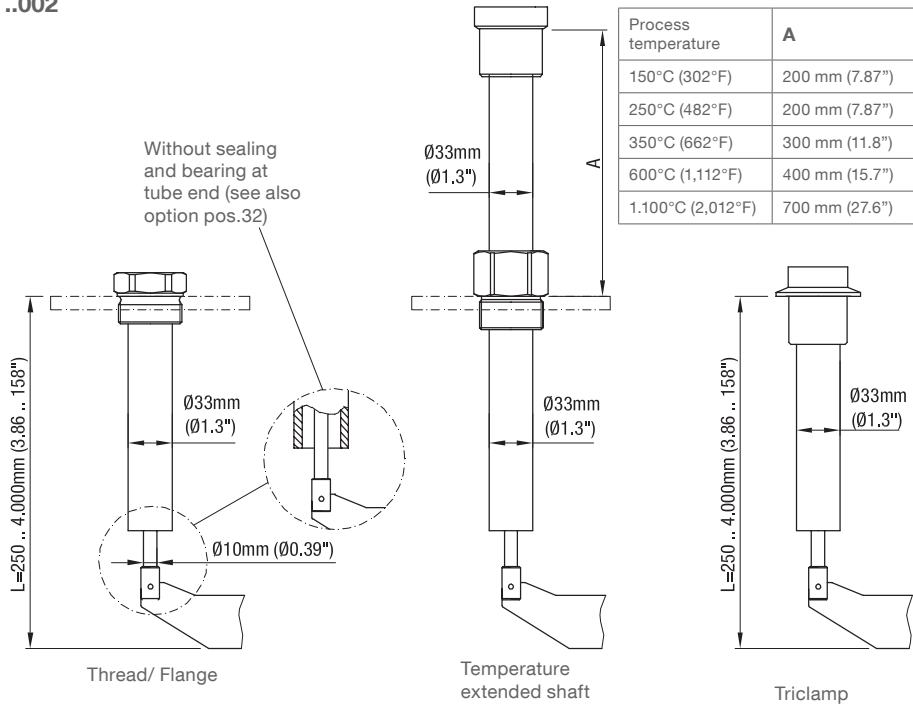

With measuring vanes "boot shaped" and "hinged vane" the length "L" can be increased by 10mm (0.39"). Details see selection code pos.10.

RN ..002 rope

Type standard (pos.1 C)
 (max. 4 kN load)

Type reinforced (pos.1 H)
 (max. 28 kN load)

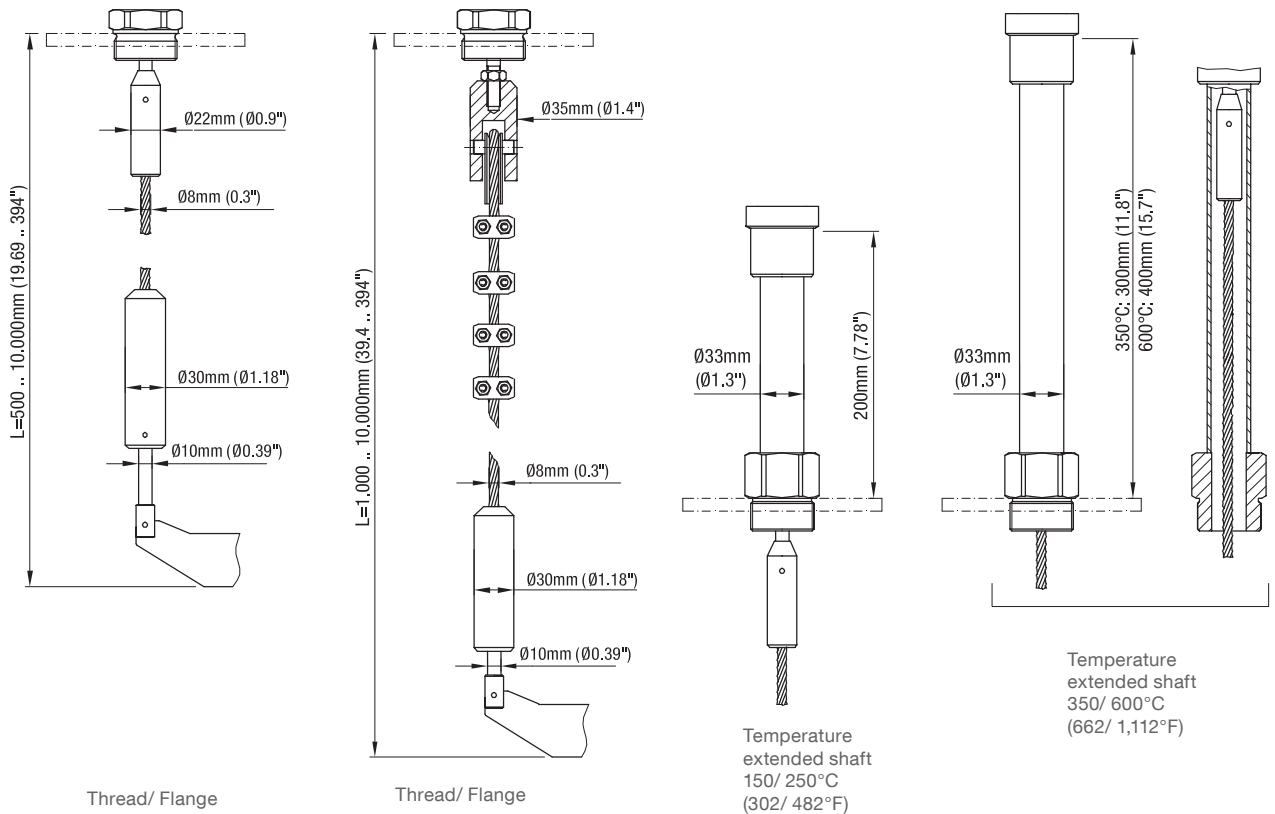

With measuring vanes "boot shaped" and "hinged vane" the length "L" can be increased by 10mm (0.39"). Details see selection code pos.10.

Technical Data

RN ..003

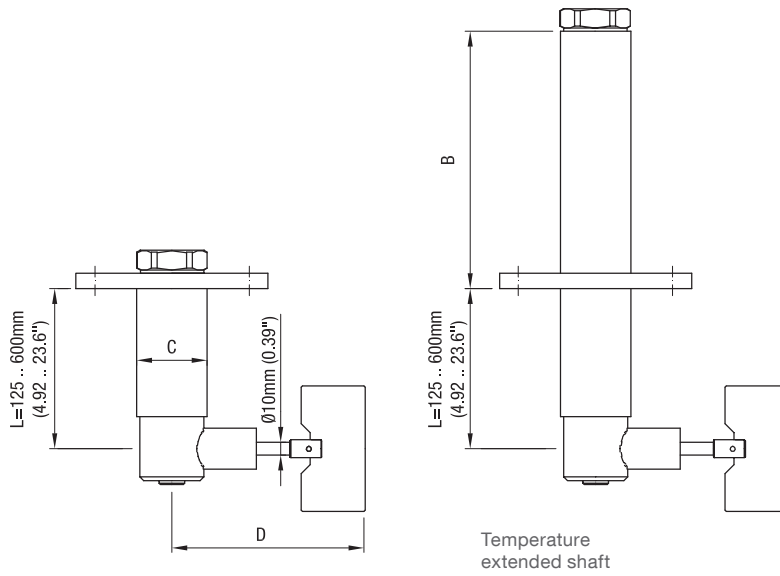

Process temperature	B
80°C (176°F) 0.8 bar (11.6 psi)	10 mm (0.39")
80°C (176°F) 5/ 10 bar (73/ 145 psi)	75 mm (2.95")
150/ 250°C (302/ 482°F) 0.8/ 5/10 bar (11.6/ 73/ 145 psi)	210 mm (8.27")

Material	C
steel	ø55 mm (ø2.17")
aluminium	ø60 mm (ø2.36")

Vane	D
50 mm x .. mm (1.97" x ..")	139 mm (5.47")
98 mm x .. mm (3.86" x ..")	187 mm (7.36")

RN ..004

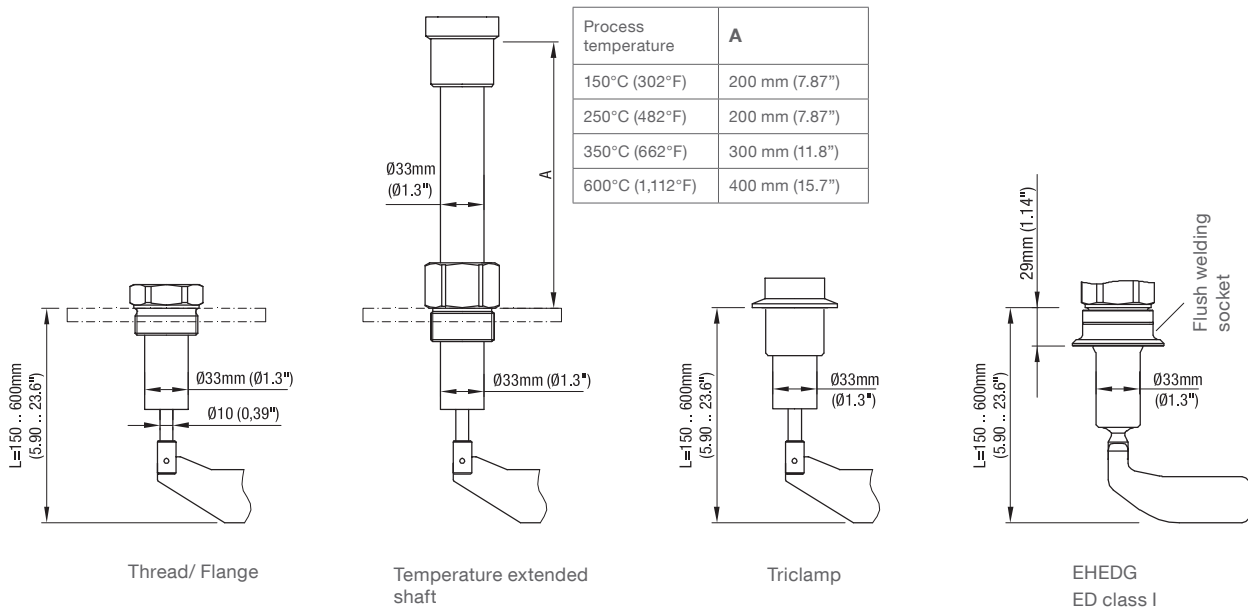

With measuring vanes "boot shaped" and "hinged vane" the length "L" can be increased by 10mm (0.39"). Details see selection code pos.10.

RN 3005

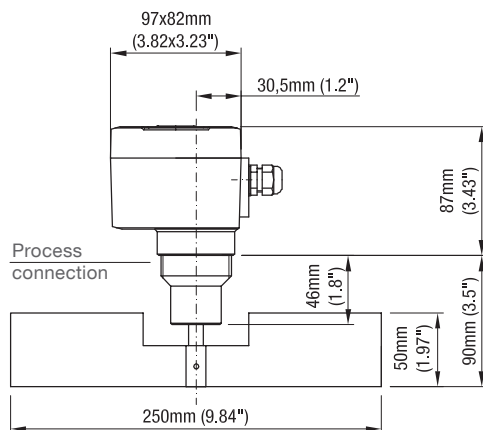

Technical Data

Measuring vanes

code	type	a	b
B	rectangular	50 mm (1.97")	98 mm (3.86")
C	rectangular	50 mm (1.97")	150 mm (5.90")
E	rectangular	50 mm (1.97")	250 mm (9.84")
F	rectangular	98 mm (3.86")	98 mm (3.86")
G	rectangular	98 mm (3.86")	150 mm (5.90")
I	rectangular	98 mm (3.86")	250 mm (9.84")

code B,C,E,F,G,I
 rectangular vane

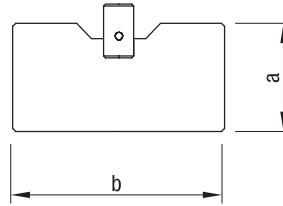

code P
 notched 40 x 80

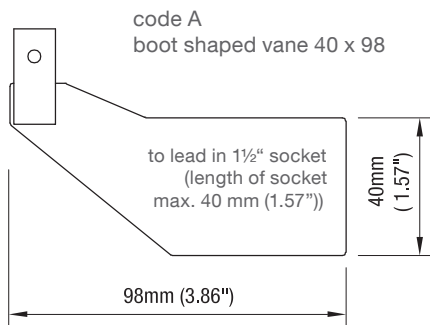
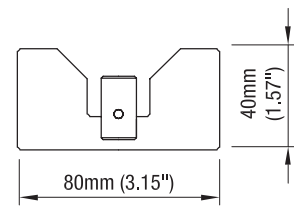

code K
 hinged vane 98 x 200 double
 sided

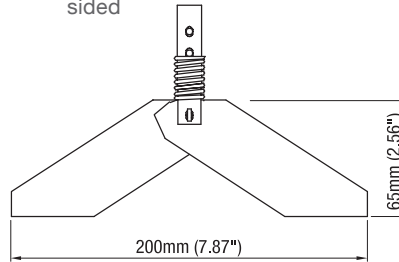

b=37 mm (1.46")
 for 1½" / 1¼"

b=28 mm (1.1")
 for 1" / M32 x 1.5

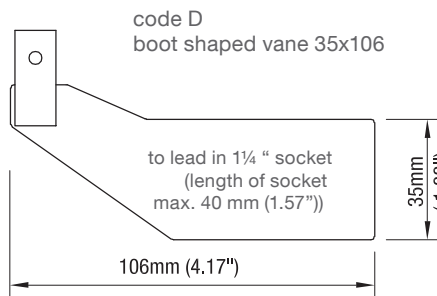

code S
 hinged vane 98 x 100
 single sided

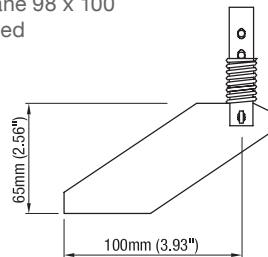

b=37 mm (1.46")
 für 1½" / 1¼"

b=28 mm (1.1")
 for 1" / M32 x 1.5

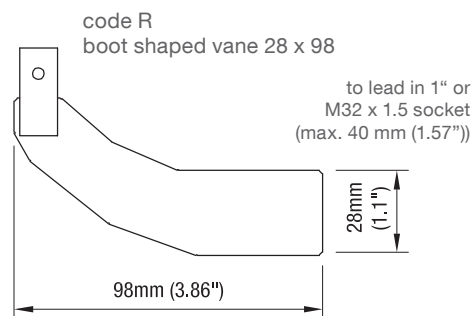

Insertion of the hinged vane
 through a long socket

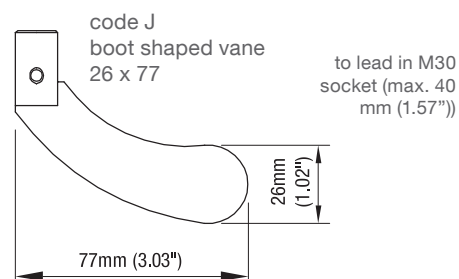
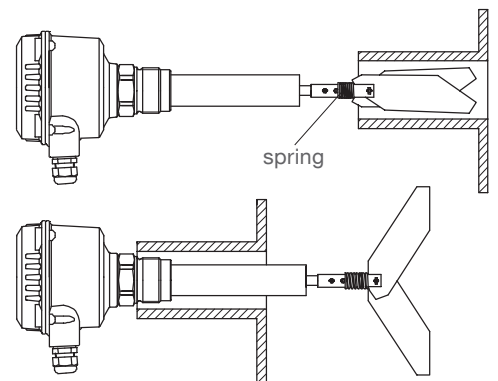

code M
 rubber vane 98 x 250

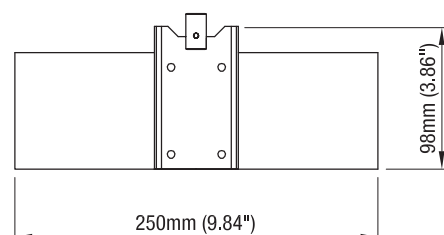

Technical Data

Electrical data

Connection terminals	see page 23/ 24
Cable entry	M20 x 1.5 screwed cable gland NPT ½" conduit connection NPT ¾" conduit connection (only RN 6000) Clamping range (diameter) of the factory provided cable glands: M20 x 1.5: 6 .. 12 mm (0.24 .. 0.47")
Protection class	I III (Version 24 V DC PNP)
Overvoltage category	II
Pollution degree	2 (inside housing)
Power supply	see page 23/ 24
Installed load	see page 23/ 24
Signal and alarm output	see page 23/ 24
Isolation	Power to signal and alarm output: 2,225 Vrms Signal output to signal output (DPDT): 2,225 Vrms
Indicating light	By built-in LED (apart from AC version)
Heating of housing	Implemented in versions Universal voltage and PNP. With temperatures below 0°C the motor dissipates power as well when it is stopped.

Mechanical data

Housing	Aluminium housing, powdercoated, RAL 5010 gentian blue RN3000: optional plastic PA6 GF, RAL 5010 gentian blue Seal between housing and lid: NBR Seal between housing and process connection: NBR Nameplate: polyester film
Degree of protection	RN 3000: IP66* RN 6000: IP66* Types with process connection and extension in stainless steel: IP66*, NEMA Type 4X (not for: RN 600x with process temperature ≥150°C (302°F), RN 6002 with sliding sleeve, RN 6003) * IEC/EN/NBR 60529. For version with plug the type of protection can be lower (see option plug/ page 15).
Material process connection (options available)	Thread: 1.4301 (304)/ 1.4305 (303) or 1.4404 (316L) or aluminium Triclamp: 1.4301 (304)/ 1.4305 (303) or 1.4404 (316L) Flange rectangle: 1.4301 (304) or aluminium Flange DN/ ANSI: 1.4541 (321) or 1.4404 (316L), DN32 also made of aluminium
Material extension (options available)	RN x001: 1.4301 (304)/ 1.4305 (303) or 1.4404 (316L) RN x002 pipe: 1.4301 (304)/ 1.4305 (303) or 1.4404 (316L) or aluminium RN x002 rope: 1.4305 (303)/ 1.4401 (316) RN x003: 1.4301 (304) or aluminium RN x004: 1.4301 (304)/ 1.4305 (303) or 1.4404 (316L) or aluminium RN 3005: 1.4305 (303) or 1.4404 (316L)
Material vane shaft	1.4301 (304)/ 1.4305 (303) or 1.4404 (316L)
Material measuring vane incl. socket (options available)	boot-shaped and rectangular vane: 1.4301 (304) or 1.4404 (316L) hinged vane 1.4301 (304)/ 1.4305 (303)/ 1.4310 (301) or 1.4404 (316L) rubber vane 1.4301 (304)/ rubber SBR
Tolerance length "L"	±10 mm (±0.39")
Sealing	Radial rotary shaft sealing Material: NBR (Nitrile Butadiene Rubber) FPM PTFE Graphite based (version 350°C (662°F) and 600°C (1,112°F))

See also selection guide on page 5.

Technical Data

Bearing	Ball bearing, dust-tight
Friction clutch	Protects the gear unit against impacts of the measuring vane
Speed of measuring vane	1 rotation or 5 rotations per minute
Sound level	max. 50 dBA

Overall weight (ca.)

RN 3000	Version				Extension	
	80°C (176°F)		150/ 250/ 350/ 600°C (302/ 482/ 662/ 1,112°F)	1,100°C (2,012°F)		
	Aluminium *	Stainl. steel *			Aluminium	Stainl. steel *
RN 3001	1.2 kg (2.6 lbs)	1.5 kg (3.3 lbs)	+1.2 kg (+2.6 lbs)	+2.8 kg (+6.2 lbs)	-	-
RN 3002	1.3 kg (2.9 lbs)	1.6 kg (3.5 lbs)	+1.2 kg (+2.6 lbs)	+2.8 kg (+6.2 lbs)	+1.3 kg/m (+2.9 lbs per 39.3")	+2.7 kg/m (+5.9 lbs per 39.3")
RN 3002- rope	2.1 kg (4.6 lbs)	2.4 kg (5.3 lbs)	+1.2 kg (+2.6 lbs)		-	+0.25 kg/m (+0.6 lbs per 39.3")
RN 3003	3.7 kg** (8.1 lbs)	6.1 kg** (13.4 lbs)	+1.2 kg (+2.6 lbs)		+0.4 kg/ 100mm (+0.9 lbs per 3.93")	+0.6 kg/ 100 mm (+1.3 lbs per 3.93")
RN 3004	1.3 kg (2.9 lbs)	1.6 kg (3.5 lbs)	+1.2 kg (+2.6 lbs)		+0.15 kg/ 100 mm (+0.3 lbs per 3.93")	+0.3 kg/ 100 mm (+0.7 lbs per 3.93")
RN 3005	1.3 kg (2.9 lbs)	1.6 kg (3.5 lbs)				

* Process connection

** Version with flange 150x150x12mm (5.9x5.9x0.47"), L=250mm (9.84")

All weights are without flanges (except RN 3003) and smallest measuring vane.

RN 6000	Version				Extension	
	80°C (176°F)		150/ 250/ 350/ 600°C (302/ 482/ 662/ 1,112°F)	1,100°C (2,012°F)		
	Aluminium *	Stainl. steel *			Aluminium	Stainl. steel *
RN 6001	1.5 kg (3.3 lbs)	1.8 kg (4.0 lbs)	+12 kg (+2.6 lbs)	+2.8 kg (+6.2 lbs)	-	-
RN 6002	1.6 kg (3.5 lbs)	1.9 kg (4.2 lbs)	+1.2 kg (+2.6 lbs)	+2.8 kg (+6.2 lbs)	+1.3 kg/m (+2.9 lbs per 39.3")	+2.7 kg/m (+5.9 lbs per 39.3")
RN 6002- rope	2.4kg (5.3 lbs)	2.7 kg (5.9 lbs)	+1.2 kg (+2.6 lbs)		-	+0.25 kg/m (+0.6 lbs per 39.3")
RN 6003	4.0 kg** (8.8 lbs)	6.4 kg** (14.1 lbs)	+1.2 kg (+2.6 lbs)		+0.4 kg/ 100 mm (+0.9 lbs per 3.93")	+0.6 kg/ 100 mm (+1.3 lbs per 3.93")
RN 6004	1.6 kg (3.5 lbs)	1.9 kg (4.2 lbs)	+1.2 kg (+2.6 lbs)		+0.15 kg/ 100 mm (+0.3 lbs per 3.93")	+0.3 kg/ 100 mm (+0.7 lbs per 3.93")

All mentioned weights are with Standard-housing.

By use of de-housing: +1.4 kg (+3.1 lbs)
 d-housing: +1.0 kg (+2.2 lbs)

* Process connection

** Version with flange 150 x 150 x 12 mm (5.9 x 5.9 x 0.47"), L=250 mm (9.84")

All weights are without flanges (except RN 6003) and smallest measuring vane.

Technical Data

Operating conditions

RN 3000:
 Ambient temp. (housing)/
 process temperature

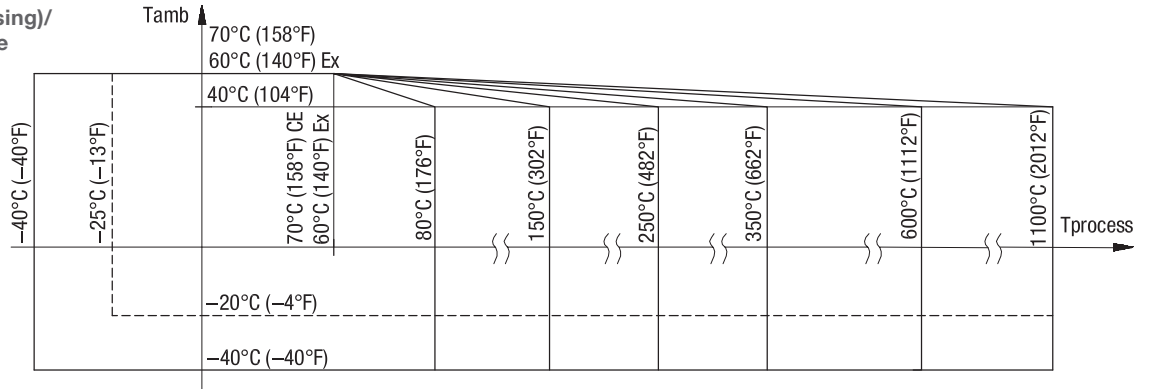

-40°C (-40°F) ambient and process temperature for version with heating of housing (pos.26)
 -40°C (-40°F) ambient temperature not for version with plastic housing in Ex Version
 +350/ 600°C (+662/ 1,112°F) process temperature not for version RN 3003, not for Ex-approvals
 +1,100°C (2,012°F) process temperature for version RN 3001, RN 3002, not for Ex-approvals
 For versions with Ex-approvals: see remarks on page 31.

RN 6000:
 Ambient temp. (housing)/
 process temperature

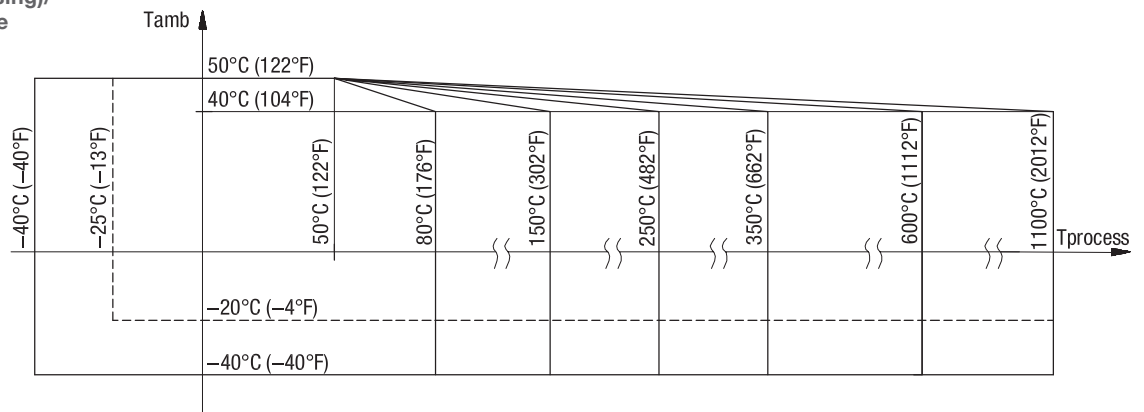

-40°C (-40°F) ambient and process temperature for version with heating of housing (pos.26)
 +350/ 600°C (+662/ 1,112°F) process temperature not for version RN6003, not for Ex-approvals
 +1,100°C (2,012°F) process temperature for version RN 6001, RN 6002, not for Ex-approvals
 For versions with Ex-approvals: see remarks on page 31.

Ventilation	Ventilation is not required		
Min. powder density/ sensitivity	see section "Sensitivity" on page 28		
Output signal delay	Version	AC, DC	Universal voltage
	Sensor free -> covered*	ca. 1.3 sec	ca. 1.5 sec + 0 .. 20 sec adjustable
	Sensor covered -> free	ca. 0.2 sec	ca. 0.2 sec + 0 .. 60 sec adjustable
	*after blocking of the measuring vane		
Features of bulk material	Hardly any limitations.		

Technical Data

Max. permitted mechanical torque

RN 3001/ 6001:

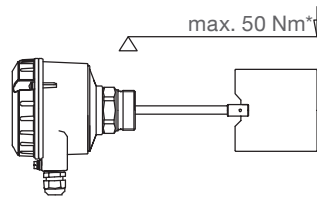

RN 3002/ 6002
 RN 3004/ 6004:

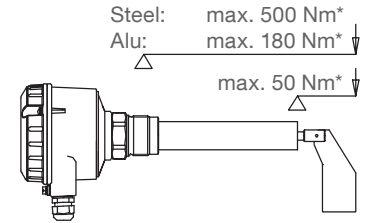

RN 3003/ 6003:

Steel: max. 600 Nm*
 Alu: max. 250 Nm*

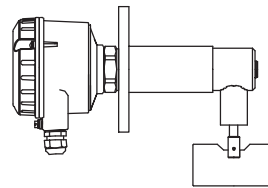

* at 40°C

For version with reinforced rib on request

Protective measures in case of high load: mounting of a protective canopy above the probe (horizontal installation) or fixing of the extension tube.

Max. tractive force	RN 3001/ 6001 pendulum shaft: RN 3002/ 6002-rope:	400 N (only applicabel as full detector) 4 kN (type standard) 28 kN (type reinforced)
Max. process pressure	-0.9 .. +0.8 bar (-13.1 .. 11.6 psi) or -0.9 .. +5 bar (-13.1 .. 73 psi) or -0.9 .. +10 bar (-13.1 .. 145 psi) -0.1 .. +0.1 bar (-1.5 .. 1.5 psi) for 600°C (1,112°F) and 1,100°C (2,012°F) version	
	For pressure over 0.8 bar (11.6 psi) the PTFE sealing is used. For versions with Ex-approvals: see remarks on page 30.	
Vibration	1.5 (m/s ²) ² / Hz according to EN 60068-2-64	
Relative Humidity	0 - 100%, suitable for outdoor use	
Altitude	RN 3000: max. 3.000 m (9,843 ft) RN 6000: max. 3.000 m (9,843 ft) max. 2.000 m (6,562 ft) with FM, CSA	
Expected product lifetime	Following parameters have a negative influence on the expected product lifetime: High ambient- and process temperature, corrosive environment, high vibration, high flow rate of abrasive bulk material passing the sensor element, high amount of measurement cycles..	

Transport and storage

Transport

Observe the instructions as stated on the transport packing, otherwise the products may get damaged.

Transport temperature: -40 .. +80°C (-40 .. +176°F)
 Transport humidity: 20 .. 85%

Transport incoming inspections must be carried out to check for possible transport damage.

Storage

Products must be stored at a dry and clean place.
 They must be protected from influence of corrosive enviroment, vibration and exposure to direct sunlight.

Storage temperature: -40 .. +80°C (-40 .. +176°F)
 Storage humidity: 20 .. 85%

Approvals

	RN 3000	RN 6000	
General Purpose * (Ordinary Locations)	• •	• •	CE EN 61010-1 (IEC/CB) UKCA FM CSA TR-CU
Hazardous Locations *	• •	• •	ATEX Dust explosion ATEX II 1/2D Ex ta/tb IIIC T! Da/Db ATEX Gas explosion flameproof ATEX II 2G Ex db IIC T! Gb flameproof/ increased safety ATEX II 2G Ex db eb IIC T! Gb
	• •	• •	UKEX Dust explosion UKEX II 1/2D Ex ta/tb IIIC T! Da/Db UKEX Gas explosion flameproof UKEX II 2G Ex db IIC T! Gb flameproof/ increased safety UKEX II 2G Ex db eb IIC T! Gb
	• •	• •	IEC-Ex Dust explosion IEC-Ex ta/tb IIIC T! Da/Db IEC-Ex Gas explosion flameproof IEC-Ex db IIC T! Gb flameproof/ increased safety IEC-Ex db eb IIC T! Gb
	• •	• •	FM Dust explosion Cl. II, III Div. 1 Gr. E,F,G FM Gas explosion flameproof XP Cl. I Div. 1 Gr. B-D Cl. I Zone 1 AEx d IIC
	• •	• •	FM Gas explosion flameproof/ increased safety Cl. I Zone 1 AEx de IIC
	• •	• •	CSA Dust explosion Cl. II, III Div. 1 Gr. E,F,G Ex DIP A20/21
	• •	• •	CSA Gas explosion flameproof XP Cl. I Div. 1 Gr. B-D Cl. I Zone 1 Ex d IIC
	• •	• •	CSA Gas explosion flameproof/ increased safety Cl. I Zone 1 Ex de IIC
	• •	• •	TR-CU Dust explosion Ex ta/tb IIIC T90°C...T250°C Da/Db X TR-CU Gas explosion flameproof 1Ex d IIC T5...T2 Gb X flameproof/ increased safety 1Ex d e IIC T5...T2 Gb X
	• •	• •	INMETRO Dust explosion Ex ta/tb IIIC T250°C...T90°C Da/Db IP6X
	• •	• •	INMETRO Gas explosion flameproof Ex db IIC T5...T2 Gb IP66 flameproof/ increased safety Ex db eb IIC T5...T2 Gb IP66
	• •	• •	KC Dust explosion Ex t IIIC T! KC Gas explosion flameproof Ex d IIC T!
	• •	• •	CCC Dust explosion Ex ta/tb IIIC T! Da/Db CCC Gas explosion flameproof Ex db IIC T! Gb
	Detailed allocation of types and electronic modules to approvals: see selection list.		
Functional safety	• •		SIL 2 (IEC 61508) The Safety Manual RN6000 must be considered when using the units in safety systems.
EMC	• •		EN 61326 - A1
Hygiene*	• •		EHEDG ED class I
Food grade material*	• •		According to directive 1935/2004/EC and Statutory Instruments S.I. 2019/704
RoHS conform	• •		According to directive 2011/65/EU and Statutory Instruments S.I. 2012/3032
Pressure Equipment Directive (PED) (2014/68/EU)	• •		As the equipment does not have pressure-bearing housings of its own, it is not subject to the PED: - as "pressure accessory" (see 2014/68/EU Art. 2 (5) and PED Guidelines A-08, A-40) - as "safety accessory" (see 2014/68/EU Art. 2 (4) and PED Guidelines A-20, A-25)

* Depending on selected version

Options

Weather protection cover

If the measuring device is used outdoors, the use of the weather protection cover is recommended. It protects the device from all atmospheric influences such as:

- rain water
- condensation water
- excessively high temperatures due to insolation
- excessively low temperatures in winter

Material: PE, weather and temperature stable



Not available for housing version d and de.
 For use in Hazardous Locations: only permitted for zone 2 and 22 or Division 2.

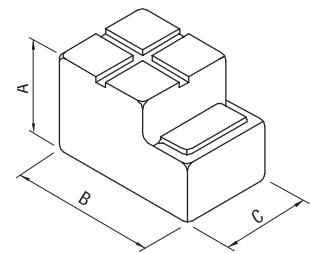

Sliding sleeve

RN 3002/ 6002 Process connection and material as chosen

Version with selection code pos.30:
 Only for applications without process pressure.
 Max. 250°C (482°F). Not available for Ex-approvals.

Version with selection code pos.31: For applications with process pressure, max. 10bar (145psi), 250°C (482°F).
 Sealing material to the extension tube: FPM.

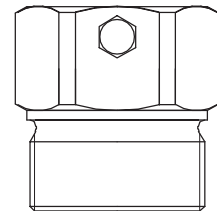

Mounting set

Screws and washers for fixing the unit on a flange.

Flat gasket

On the face sealing of the process connection thread.
 Incl. sealing face for version with G 1½" thread.

Max. 250°C (482°F)

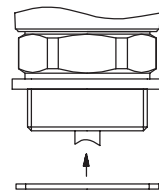

LED (Glass window in lid)

To see the indicating light on the electronic module from outside.

Not available for housing version d and de.

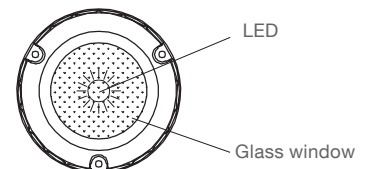

Control lamp

Bright indicating light (LED) seen from outside.

Not available for use in Hazardous Locations.

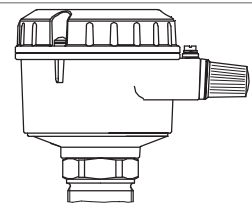

Plug

Used instead of cable gland.

Not available for use in Hazardous Locations and FM/ CSA general purpose.

Connection of the plug wires to the internal terminals of the unit must be done on site or according to customer demands.

Valve connector (incl. mating plug)

4-pole (incl. PE), max. 230 V, enclosure plastic, IP65

Plug M12 (without mating plug)

4-pole, max. 25 V or 5-pole, max. 60 V
 Enclosure brass, IP66

Plug Han 4A (incl. mating plug)

5-pole (incl. PE), max. 230 V, enclosure zinc, IP65

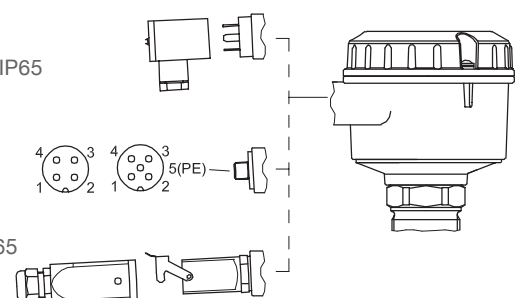

Options / Mounting

EHEDG approval	EHEDG (ED class I) conform design (material and construction in contact with the process). Approved with flush welding socket Material: 1.4404 (316L) (details see: mounting instructions EHEDG version, page 17).
-----------------------	---

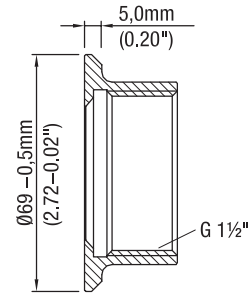

Food grade material	Food grade material in contact with the process food (sealing and grease FDA conform). The option does not automatically implement a food conform design (food conform gaps, surface and radiuses).
----------------------------	---

Mounting

! General Safety Instructions

Process pressure	Improper installation may result in loss of process pressure.
Chemical resistance against the medium	Materials of construction are chosen based on their chemical compatibility (or inertness) for general purposes. For exposure to specific environments, check with chemical compatibility charts before installing.
Mechanical load	The torque at the fastening spot must not exceed the specified ratings. See page 12 for details.
Mounting location	Keep away from incoming material and from silo walls. The installation has to be carried out, that the sensor elements cannot hit the wall of the silo. The flow of the medium and fixtures in the container must be considered. This is especially important for extension length of more than 3000 mm (118")

Sliding sleeve	Tighten both straining screws accordingly to obtain resistance against process overpressure: Process overpressure max. 0.8 bar (11.6psi)*: 5 Nm Process overpressure max. 5/10 bar (73/145psi)*: 12 Nm * see marking on typeplate
-----------------------	--

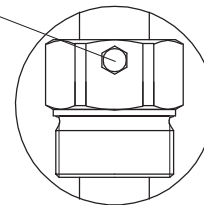

Flange mounting	A plastic seal must be used to tighten the flange.
EHEDG-approval/ Food grade material	The materials are available for the use under normal and predictable applications (according to directive 1935/2004 Art.3). Other conditions can influence the safety.

! Additional Safety Instructions for Hazardous Locations

Installation regulations	For devices to be used in Hazardous Locations the respective valid installation regulations must be observed.
Sparks	The installation has to be done in a way, that mechanical friction or impact does not cause sparks between the aluminium enclosure and steel.

Mounting

Mounting instructions

Rotatable housing

The housing can be rotated against the threaded connection after mounting.

RN 6000: For the d- and de- housing:
 Fixing screw must be unfastened to enable rotation. Fix the screw again, when the housing has the right position.

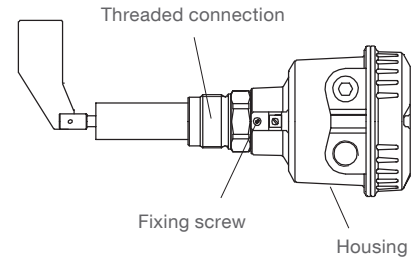

Direction of the cable glands When the unit is mounted from the side, ensure, that the cable glands face downwards and are closed to avoid water penetration into the housing.

Sealing Seal the process connection thread with PTFE sealing tape against process pressure. Alternative use of a flat gasket is possible (option pos. 15)

Precaution for later dismantling/ Service

- Use PTFE sealing tape to avoid seizing of aluminium process connection thread with the socket
- Grease the screws of the lid if corrosive atmosphere is present (e.g. close to sea)

EHEDG (ED class I) Approval

Metal-metal sealing:

- The support must be without any gap. No PTFE sealing tape (or similar) is allowed to be in between.
- Fixing torque 100 Nm

The quality of the welding with the container wall must be according to the respective regulations (e.g. gaps, transitions, surface finish).

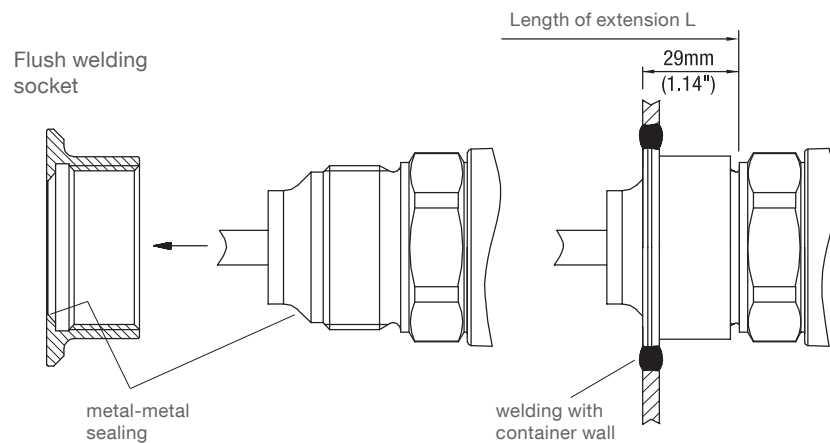

Dimension of flush welding socket (for optional on site manufacturing):

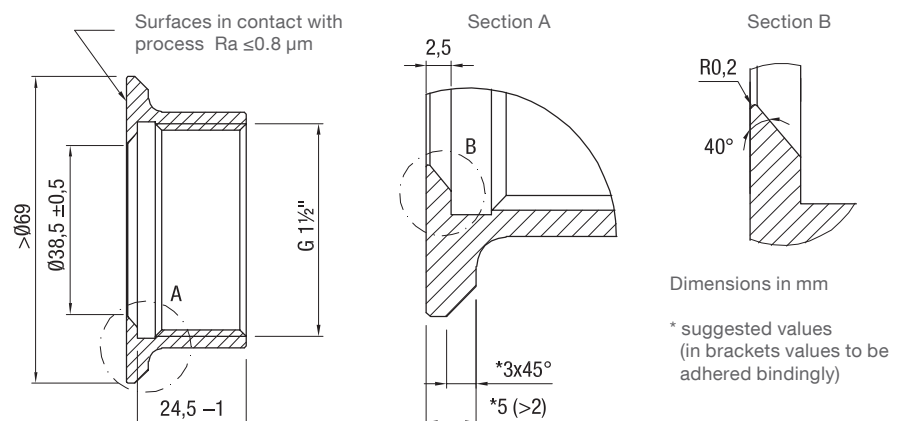

Mounting

RN 3001
 RN 6001

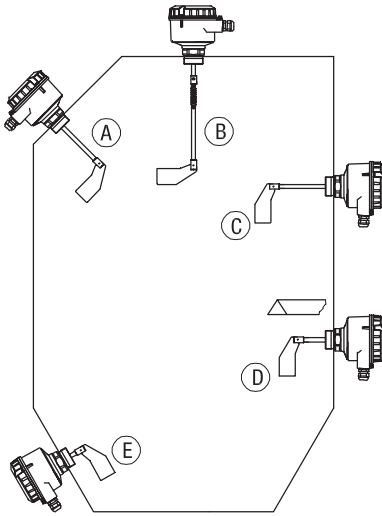

- A Full detector vertical and oblique from the top
max. „L“=600 mm (23.62”)
- B With pendulum shaft or rope extension: Full detector vertical from the top. Observe max. pulling force.
- C Full detector horizontal
max. „L“=300 mm (11.8”)
- D Demand or empty detector horizontal
max. „L“=150 mm (5.9”)
Protective angle recommended depending on load.
- E Empty detector oblique from the bottom
max. „L“=150 mm (5.9”)
Protective angle recommended depending on load.

Horizontal mounting: Boot shaped vane recommended (min. mech. load, because the vane aligns to the movement of the material).

RN 3002
 RN 6002

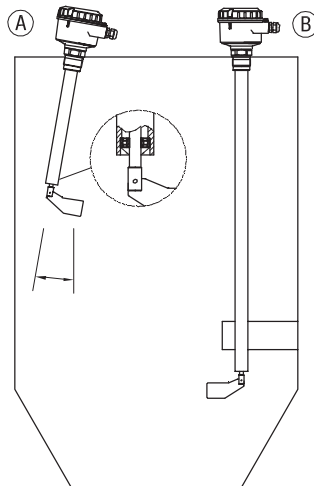

- A Full detector vertical from the top
max. „L“=3,000 mm (118“)

Remark:
 Deviation up to max. 10° from vertical installation with option „Bearing at tube end“ possible.

- B Full detector vertical from the top
max. „L“=4,000 mm (158“)

Support from side recommended.

RN 3002-Rope
 RN 6002-Rope

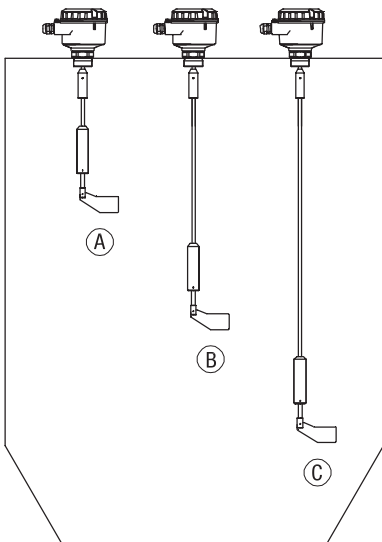

- A Full detector vertical
- B Demand detector vertical
- C Empty detector vertical

max. „L“=10,000 mm (394“)
 Observe max. tractive force.

Mounting

RN 3003
RN 6003

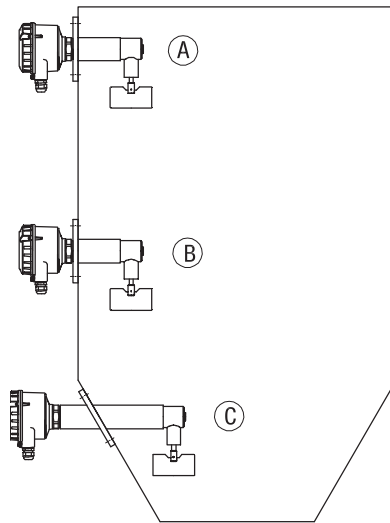

- A Full detector horizontal
- B Demand detector horizontal
- C Empty detector horizontal

Protective angle recommended depending on load.

RN 3004
RN 6004

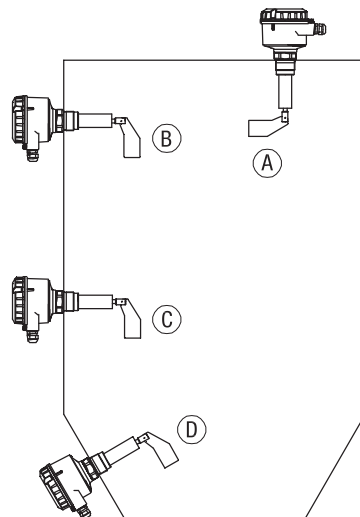

- A Full detector vertical and oblique from the top
- B Full detector horizontal
- C Demand or empty detector horizontal
Protective angle recommended depending on load.
- D Empty detector oblique from the bottom
Protective angle recommended depending on load.

Horizontal mounting: Boot shaped vane recommended (min. mech. load, for the vane aligns to the movement of the material).

Electrical installation

! General Safety Instructions

Handling	In the case of improper handling or handling malpractice, the electric safety of the device cannot be guaranteed.
Installation regulations	The local regulations must be observed. With use of 24 V supply voltage, an approved power supply with reinforced insulation to mains is required.
Fuse	Use a fuse as stated in the connection diagrams (see pages 23 and 24).
RCCB protection	In the case of a fault, the supply voltage must be automatically switched off by a RCCB protection switch to protect against indirect contact with dangerous voltages.
Power supply switch	A voltage disconnection switch must be provided near the device.
Wiring diagram	The electrical connections are made in accordance with the wiring diagram.
Supply voltage	Compare the supply voltage applied with the specifications given on the electronic module and name plate before switching the device on.
Cable gland	The screwed cable gland and closing element must have following specifications: Ingress protection IP66, temperature range from -40°C to +70°C, certified depending on the country where the unit is installed, pull relief. Make sure that the screwed cable gland safely seals the cable and that it is tight (danger of water intrusion). Cable glands that are not used have to be sealed with a blanking element. The diameter of the field wiring cable has to match to the clamping range of the used cable gland.
Conduit system	In case of using a conduit system (with NPT thread) instead of a cable gland the regulations of the country, where the unit is installed, must be observed. The conduit must have a tapered thread either NPT 1/2" or NPT 3/4" in accordance with the unit and ANSI B 1.20.1. Not used inlets must be closed tight with a metal blanking element.
Field wiring cables	<ul style="list-style-type: none"> • The diameter has to match to the clamping range of the used cable gland. • The cross section has to match with the clamping range of the connection terminals and consider the max. current. • All field wirings must have insulation suitable for at least 250 V AC. • The temperature rating must be at least 90°C (194°F). • If higher immunity interferences as specified in the stated EMC standards are present (see chapter approval), a shielded cable is required, otherwise an unshielded instrumentation cable is satisfactory.
Guiding the cables in the terminal box	Cut the field wiring cables to appropriate length to fit properly into the terminal box.
Microswitch protection	Provide protection for microswitch contacts to protect the device against inductive load surges.
Protection against static charging	The housing of the unit must be grounded to avoid static charging of the unit. This is particularly important for applications with pneumatic conveying and non-metallic containers.

! Additional Safety Instructions for Hazardous Locations

External equipotential bonding terminal

RN 3000

RN 6000

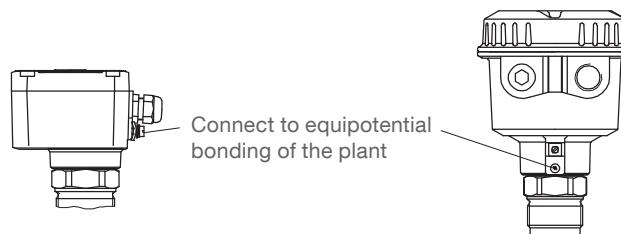

Electrical installation

Field wiring	A strain relief must be provided for the field wiring cables, when the device is installed with the factory provided cable glands.										
Field wiring terminals for "de" housing	<p>Fixing torque : 0.5 - 0.6 Nm Remove wire isolation: 9 mm</p> <p>Conductor cross section</p> <table border="0"> <tr> <td>1 conductor</td> <td>2 conductors with same cross section</td> </tr> <tr> <td>- solid: 0.2 to 2.5 mm²</td> <td>- solid: 0.2 to 0.75 mm²</td> </tr> <tr> <td>- flexible: 0.2 to 2.5 mm²</td> <td>- flexible: 0.2 to 0.75 mm²</td> </tr> <tr> <td>- flexible, with ferrule with or without plastic sleeve: 0.25 to 1.5 mm²</td> <td>- flexible, with ferrule without plastic sleeve: 0.25 to 0.34 mm²</td> </tr> <tr> <td>- AWG 24 to 14</td> <td></td> </tr> </table>	1 conductor	2 conductors with same cross section	- solid: 0.2 to 2.5 mm ²	- solid: 0.2 to 0.75 mm ²	- flexible: 0.2 to 2.5 mm ²	- flexible: 0.2 to 0.75 mm ²	- flexible, with ferrule with or without plastic sleeve: 0.25 to 1.5 mm ²	- flexible, with ferrule without plastic sleeve: 0.25 to 0.34 mm ²	- AWG 24 to 14	
1 conductor	2 conductors with same cross section										
- solid: 0.2 to 2.5 mm ²	- solid: 0.2 to 0.75 mm ²										
- flexible: 0.2 to 2.5 mm ²	- flexible: 0.2 to 0.75 mm ²										
- flexible, with ferrule with or without plastic sleeve: 0.25 to 1.5 mm ²	- flexible, with ferrule without plastic sleeve: 0.25 to 0.34 mm ²										
- AWG 24 to 14											
Cable glands (Dust and Gas Hazardous Locations)	<p>Installation according to the regulations of the country, where the product is installed.</p> <p>Not used entries have to be closed with blanking elements certified for this purpose.</p> <p>Where available the factory provided parts must be used.</p> <p>A strain relief must be provided for the field wiring cables, when the device is installed with the factory provided cable glands.</p> <p>The diameter of the field wiring cable must match to the clamping range of the cable clamp.</p> <p>If other than the factory provided parts are used, following must be ensured: The parts must have an approval adequate to the approval of the level sensor (certificate and type of protection). The approved temperature range must be from the min. ambient temperature of the level sensor to the max. ambient temperature of the level sensor increased by 10 Kelvin. The parts must be mounted according to the instructions of the supplier.</p>										
Conduit system (Dust and Gas Hazardous Locations)	<p>General requirements: In addition the regulations of the country must be observed. The used flameproof seals and blanking elements must have an adequate type approval and a temperature range of at least -40°C (-40°F) to +80°C (176°F). In addition they shall be suitable for the conditions and correctly installed. Where available the provided original parts of the manufacturer must be used.</p> <p>Installation of a flameproof/ explosion proof enclosure with a conduit system: In a conduit system single electric conductors are installed in a certified pipe system. This pipe system is in a flameproof/ explosion proof construction as well. The flameproof/ explosion proof enclosure and the pipe system needs to be sealed from each other by a certified flameproof seal of a type "d" or explosion proof of a type "XP". This seals shall be installed directly in or at the conduit entries of the flameproof/ explosion proof enclosure. Not used entries have to be closed with blanking elements certified for this purpose (flameproof type "d" or explosion proof type "XP").</p> <p>Additional requirements for FM and CSA: Conduit entries of a flameproof enclosure "d" shall have installed the flameproof seal within 18 inches from the enclosure wall. Not used entries have to be closed with adequate blanking elements of a certified flameproof type AEx Cl.1 Div.1 A.</p>										
Commissioning	Commissioning only with closed lid.										
Opening the lid	<p>Units with Dust Explosion approval: Before opening the lid take care, that no dust deposits or whirlings are present. Do not remove the lid (cover) while circuits are alive.</p> <p>RN 6000:</p> <p>Units with flameproof GasExplosion approval (d-housing): To prevent ignition of hazardous atmospheres, do not remove the lid (cover) while circuits are alive.</p>										

Electrical installation

Connection

RN 3000: Standard housing

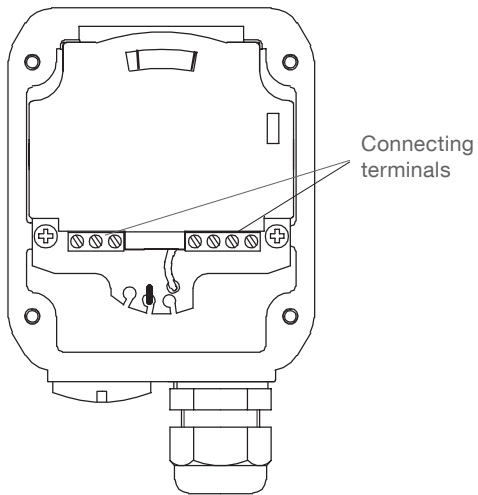

RN 6000: Standard and d-housing

Connection is done directly on the PCB

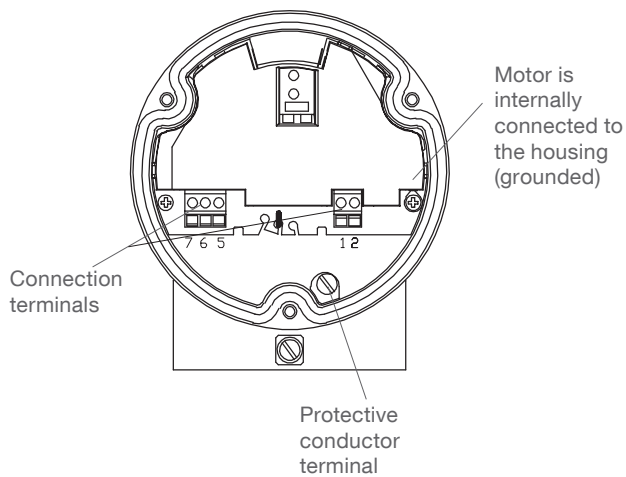

de-housing

Connection is done on the terminals inside the increased safety area.

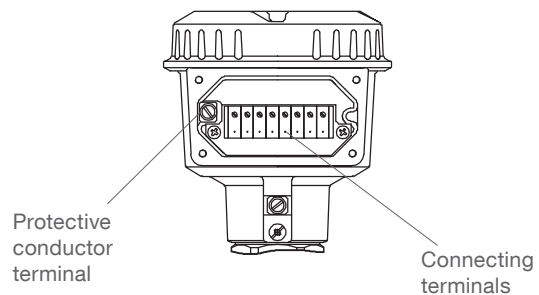

Electrical installation Series RN 3000

Version:

- AC
- DC
- **Universal voltage**

Power supply:

- **AC version:**
 24 V or 48V or 115 V or 230 V 50/ 60 Hz max. 4 VA
 All voltages $\pm 10\%$ ⁽¹⁾
 Supply voltage as selected.
 External fuse: max. 10 A, fast or slow, HBC, 250 V
- **DC version:**
 24 V DC $\pm 15\%$ ⁽¹⁾ max. 2.5 W
 External fuse: not required
- **Universal voltage:**
 24 V DC $\pm 15\%$ ⁽¹⁾ max. 4 W
 22 .. 230V 50/ 60 Hz $\pm 10\%$ ⁽¹⁾ max. 10 VA
 External fuse: not required

⁽¹⁾ including $\pm 10\%$ of EN 61010

Signal and alarm output:

Micro switch or relay, SPDT contact
 max. 250 V AC, 2 A, 500 VA ($\cos\phi = 1$)
 max. 250 V DC, 2A, 60 W
 External fuse: max. 10 A, fast or slow, HBC, 250 V

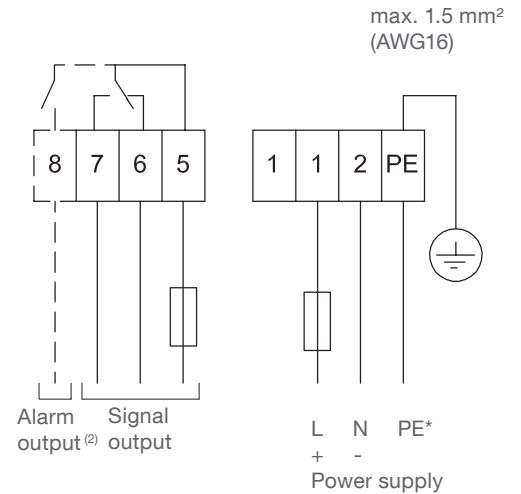

⁽²⁾ With option Fail safe alarm (rotation control)
 Contact open when de-energised

Version: - PNP

Power supply:

24 V DC $\pm 15\%$ ⁽¹⁾
⁽¹⁾ including $\pm 10\%$ of EN 61010
 Input current: max. 0.6 A

Signal output:

Load max. 0.4 A
 Output voltage equal to input voltage, drop <2.5 V
 Open collector
 Protected against short circuit and overload

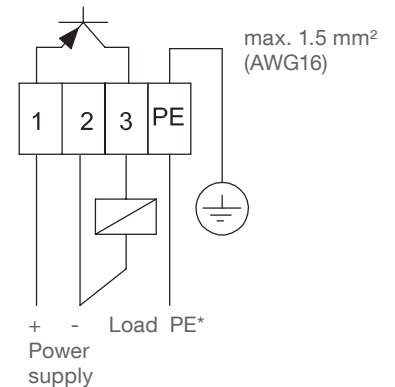

* Protection against static charge:

The PE terminal of the unit must be grounded to avoid static charging of the unit.
 This is particularly important for applications with pneumatic conveying.

Electrical installation Series RN 6000

Version:

- AC
- DC

Power supply:

- **AC version:**
 24 V or 48 V or 115 V or 230V 50/ 60 Hz max. 4 VA
 All voltages $\pm 10\%$ ⁽¹⁾
 Supply voltage as selected.
 External fuse: max. 10 A, fast or slow, HBC, 250 V

- **DC version:**
 24 V DC $\pm 15\%$ ⁽¹⁾ max. 2.5 W
 External fuse: not required

⁽¹⁾ including $\pm 10\%$ of EN 61010

Signal output:

Micro switch, SPDT contact
 max. 250 V AC, 5 A, non inductive
 max. 30 V DC, 4 A, non inductive
 External fuse: max. 10 A, fast or slow, HBC, 250 V

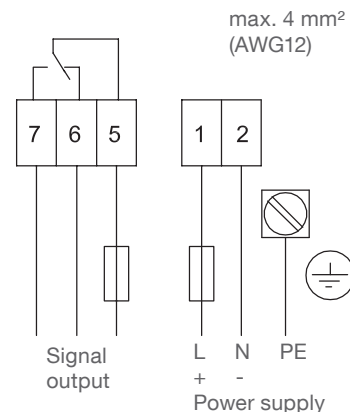

Version:

- Universal voltage
 (without SIL 2)

Power supply:

24 V DC $\pm 15\%$ ⁽¹⁾ max. 4 W
 22 .. 230 V 50/ 60 Hz $\pm 10\%$ ⁽¹⁾ max. 10 VA

⁽¹⁾ including $\pm 10\%$ of EN 61010

Signal and alarm output:

Relay DPDT contact
 max. 250 V AC, 5 A, non inductive;
 max. 30 V DC, 4 A, non inductive
 External fuse: max. 10 A, fast or slow, HBC, 250 V

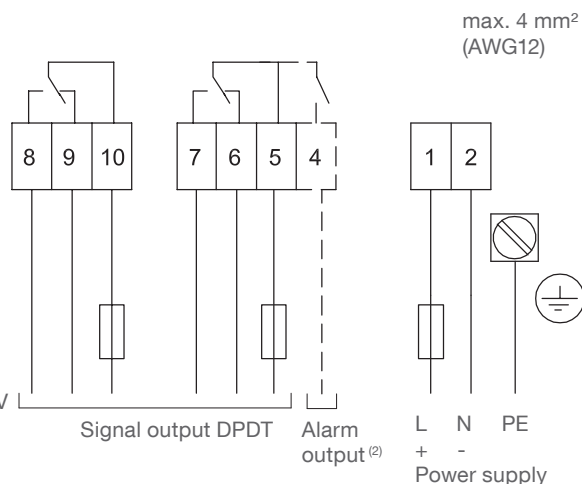

⁽²⁾ With option Fail safe alarm (rotation control)
 Contact open when de-energised

Version:

- Universal voltage
 SIL 2

Power supply:

24 V DC $\pm 15\%$ ⁽¹⁾ max. 4 W
 22 .. 230 V 50/ 60 Hz $\pm 10\%$ ⁽¹⁾ max. 10 VA

⁽¹⁾ including $\pm 10\%$ of EN 61010

Signal output:

Relay SPST/ SPDT
 max. 250 V AC, 5 A, non inductive;
 max. 30 V DC, 4 A, non inductive
 External fuse: max. 10 A, fast or slow, HBC, 250 V

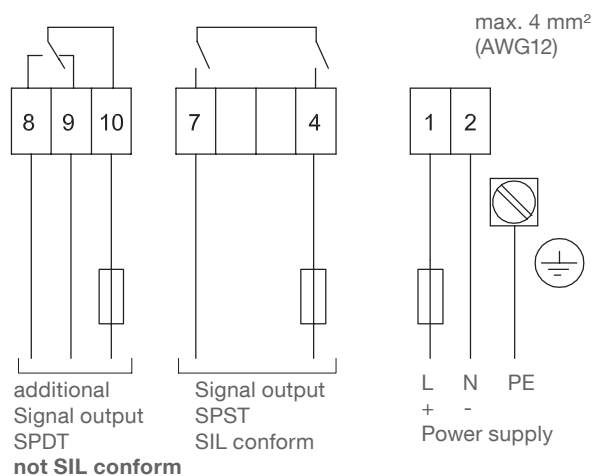

additional Signal output SPDT
 not SIL conform



* Protection against static charge:

- The PE terminal of the unit must be grounded to avoid static charging of the unit.
- This is particularly important for applications with pneumatic conveying.

Signal and alarm output

Overview

Overview of signal and alarm output for the different electronic versions: see page 5

Signal output: Switching logic

Version • RN 3000: AC, DC
 • RN 6000: AC, DC

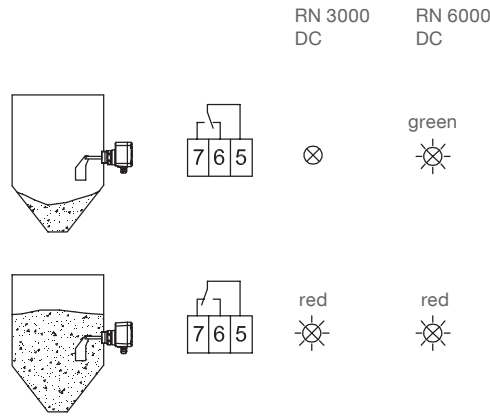

Version • RN 3000: Universal voltage, PNP
 • RN 6000: Universal voltage (without SIL 2)

FSH: Use this setting when sensor is used as a full detector.

Power failure or line break is regarded as „full“ signal (protection against overflowing).

FSL: Use this setting when sensor is used as an empty detector.

Power failure or line break is regarded as „empty“ signal (protection against running dry).

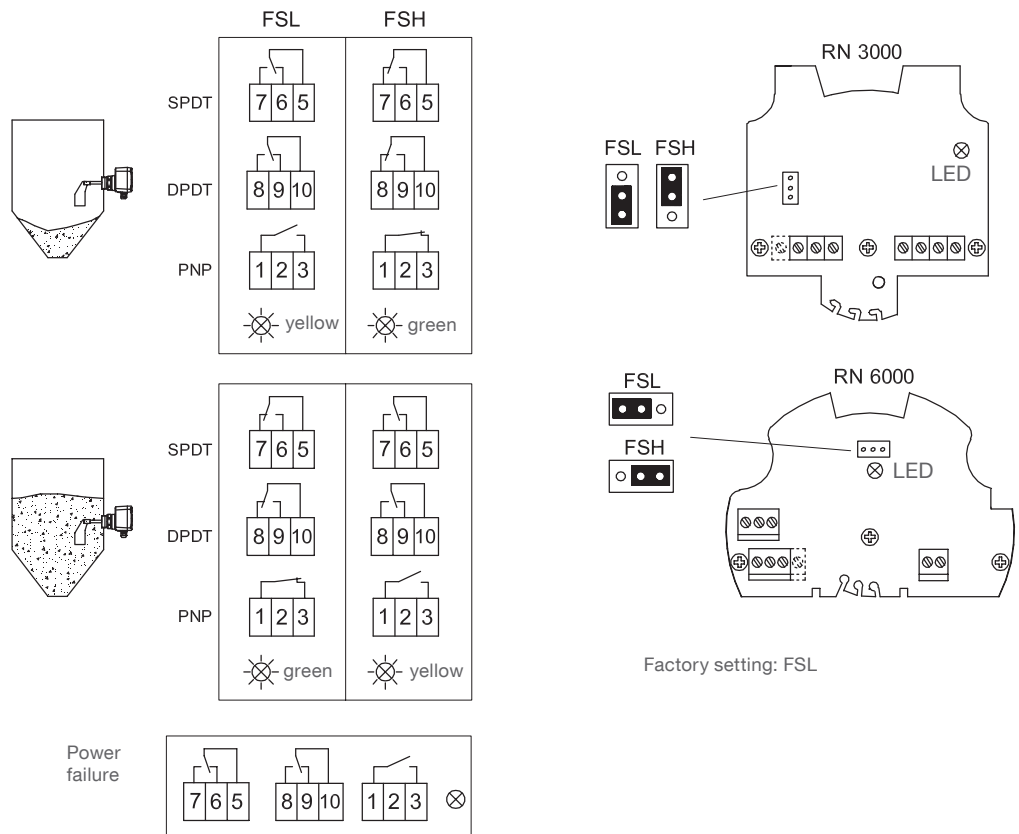

Signal and alarm output

Version • **RN 6000: Universal voltage SIL 2**

FSH: Use this setting when sensor is used as a full detector.
 Power failure or line break is regarded as „full“ signal (protection against overfilling).

FSL: Use this setting when sensor is used as an empty detector.
 Power failure or line break is regarded as „empty“ signal (protection against running dry).

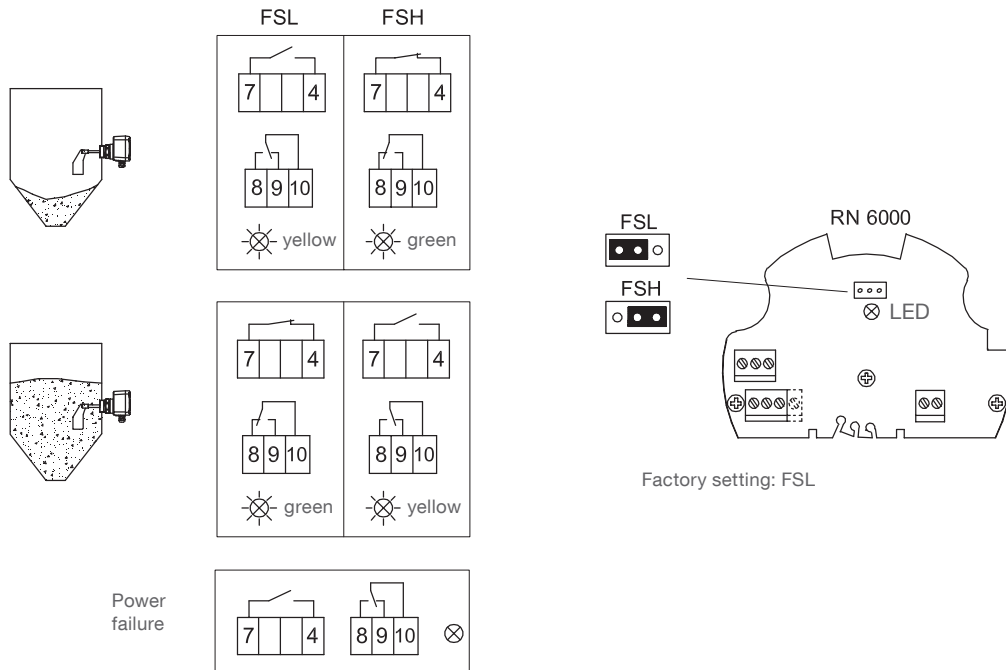

Signal and alarm output

Signal output: Delay

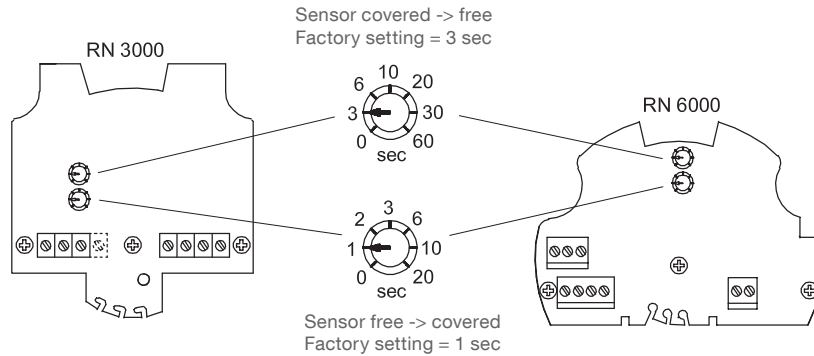

Alarm output (Fail safe alarm, Rotation control)

Switching and timing behaviour:

If the sensor is not covered, the rotating paddle shaft will send pulses at 20 sec intervals. In case of fault, the pulses are missed. After 30 sec the alarm relay will open.

RN 3000 Universal voltage

yellow or green
 (see page before)

red



No fault



Fault

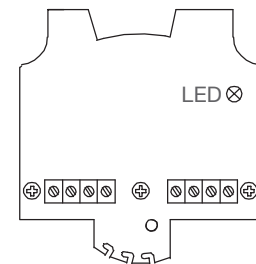

RN 6000 Universal voltage (without SIL 2)

yellow or green
 (see page before)

red



No fault



Fault

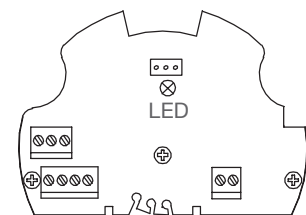

Connection example:

Full detector with maximum safety:
 The output signal opens in case of:

- full signal or
- failure of supply voltage or
- defect of the connection wires or
- defective unit

RN3000

RN6000

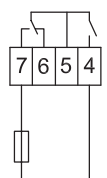
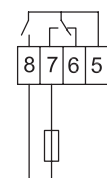

Signal output

Settings: Sensitivity

Adjustment of the spring

The spring is adjustable in 3 positions. It should be changed only if necessary.

- „Fine“: for light material
- „Medium“: suitable for nearly every material (factory setting)
- „Coarse“: for very sticky material

The spring can be changed via a small plier.

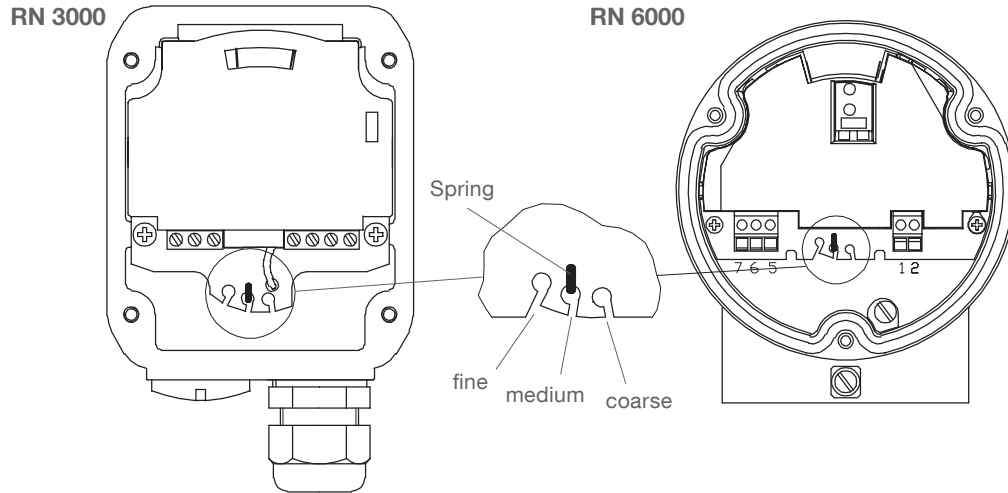

Sensitivity

The table shows approximate values for the minimum densities, at which a normal function should be possible.

Vane	*Minimum density in g/l = kg/m ³ (lb/ft ³) (without guarantee)			
	Vane completely covered with bulk material		Bulk material is 100 mm (3.93") above covered vane	
	Spring adjustment		Spring adjustment	
	fine	medium (factory setting)	fine	medium (factory setting)
Boot shaped vane 40 x 98	200 (12)	300 (18)	100 (6)	150 (9)
Boot shaped vane 35 x 106	200 (12)	300 (18)	100 (6)	150 (9)
Boot shaped vane 28 x 98	300 (18)	500 (30)	150 (9)	200 (12)
Boot shaped 26 x 77	350 (21)	560 (33)	200 (12)	250 (15)
Vane 50 x 98	300 (18)	500 (30)	150 (9)	250 (15)
Vane 50 x 150	80 (4,8)	120 (7.2)	40 (2.4)	60 (3.6)
Vane 50 x 250	30 (1.8)	50 (3)	15 (0,9)	25 (1.5)
Vane 98 x 98	100 (6)	150 (9)	50 (3)	75 (4.5)
Vane 98 x 150	30 (1.8)	50 (3)	15 (0,9)	25 (1,5)
Vane 98 x 250	20 (1.2)	30 (1.8)	15 (0,9)	15 (0,9)
Hinged vane 98 x 200 b=37 double sided	70 (4.2)	100 (6)	35 (2.16)	50 (3)
Hinged vane 98 x 200 b=28 double sided	100 (6)	150 (9)	50 (3)	75 (4.5)
Hinged vane 98 x 100 b=37 single sided	200 (12)	300 (18)	100 (6)	150 (9)
Hinged vane 98 x 100 b=28 single sided	300 (18)	500 (30)	150 (9)	250 (15)



The above mentioned data is a guideline and is for loose, non compacted material. During the filling the bulk density can change (e. g. for fluidised material).



*For versions with option 26 (heating of housing) the above mentioned data must be multiplied by 1.5 (due to high friction on the shaft seal with low temperatures, a stronger spring is used).

Maintenance

- Opening the lid (cover)**  Before opening the lid for maintenance reasons observe following items:
- Do not remove the lid while circuits are live.
 - No dust deposits or whirlings are present.
 - No rain can enter into the housing.

- Frequent check of the unit**  To ensure durable safety in hazardous locations and with electrical safety, following items must be checked frequently depending on the application:
- Mechanical damage or corrosion of any components (housing side and sensor side) and of the field wiring cables.
 - Tight sealing of the process connection, cable glands and enclosure lid..
 - Properly connected external PE cable (if present).

- Cleaning**  If cleaning is required by the application, following must be observed:
- Cleaning agent must comply with the materials of the unit (chemical resistance). Mainly the shaft sealing, lid sealing, cable gland and the surface of the unit must be considered.
-  The cleaning process must be done in a way, that:
- The cleaning agent cannot enter into the unit through the shaft sealing, lid sealing or cable gland.
 - No mechanical damage of the shaft sealing, lid sealing, cable gland or other parts can happen.
- Units with EHEDG certification, which are used in the respective EHEDG applications, must be cleaned dry only (ED class I). Furthermore the respective regulations must be observed.
- Units with explosion certification (not valid if units have as well EHEDG certification):
 A possible accumulation of dust on the unit does not increase the maximum surface temperature and must therefore not be removed for purposes of maintaining the surface temperature in hazardous locations.

- Function test**  A frequent function test may be required depending on the application.
- Observe all relevant safety precautions related with a safe work depending on the application (e.g. hazardous locations, hazardous bulk material, electrical safety, process pressure).
- This test does not proof if the sensor is sensitive enough to measure the material of the application.
-  Function test is done by stopping the rotating paddle with appropriate means and monitor if a correct change of the signal output from uncovered to covered happens.

- Production date** The production date can be traced by the serial number on the typeplate. Please contact the manufacturer or your local distributor.

- Spare parts** All available spare parts are stated in the selection list.

Notes for use in Hazardous Locations

Zone classification

	Useable in zone	Category	Equipment Protection Level (EPL)
Dust applications	20, 21, 22	1 D	Da
	21, 22	2 D	Db
	22	3 D *	Dc
Gas applications	0, 1, 2	1 G	Ga
	1, 2	2 G	Gb
	2	3 G	Gc

*) in case of conductive dust additional requirements for the installation are necessary.

General Notes

Marking Devices with Ex approval are marked on name plate.

Process pressure  Devices with Ex Approval are approved for atmospheric pressure. A detailed explanation is given below for ATEX and applies analogously for other Ex approvals:

- The scope of the ATEX directive is generally limited to atmospheric pressure, see ATEX directive 2014_34_EU Chapter 1 Art.2 (4). Atmospheric pressure is defined as absolute pressure 0.8bar to 1.1bar, see ATEX guideline §50 and IEC 60079-0 chapter 1 Scope.

The technical background is that an explosive atmosphere which is compressed (overpressure) or released (underpressure) can exhibit different explosion behaviour than under atmospheric conditions. The standards for the types of protection against explosion (IEC 60079 series), on which a type approval according to the ATEX directive is based, are designed for atmospheric conditions and do not automatically cover deviating pressure conditions.

Thus, an ATEX type approval issued in accordance with this directive only covers atmospheric pressure. This applies to all manufacturers. A deviating operating pressure can be assessed and approved by an expert for the respective application. Regardless of this, the design of the level indicators is suitable for a vessel overpressure / underpressure in accordance with the specified technical data.

Process and ambient temperature The permitted temperature ranges are marked on the name plate. The max. permitted ambient and process temperatures (including temperature derating) stated in this manual must be observed.

ATEX/ UKEX: Year of manufacturing

Marking on the name plate is done according to IEC 60062 as follows:

Year of manufacturing	2018	2019	2020	2021	2022	2023	2024	2025	2026	2027	2028	2029
Marking code	K	L	M	N	P	R	S	T	U	V	W	X

Specific conditions of use

Electrostatic charge The apparatus shall be installed in a way that danger caused by electrostatic charges is avoided.

Flameproof joints The flameproof joints are not intended to be repaired.

Notes for use in Hazardous Locations

Permitted zones for mounting in partition wall

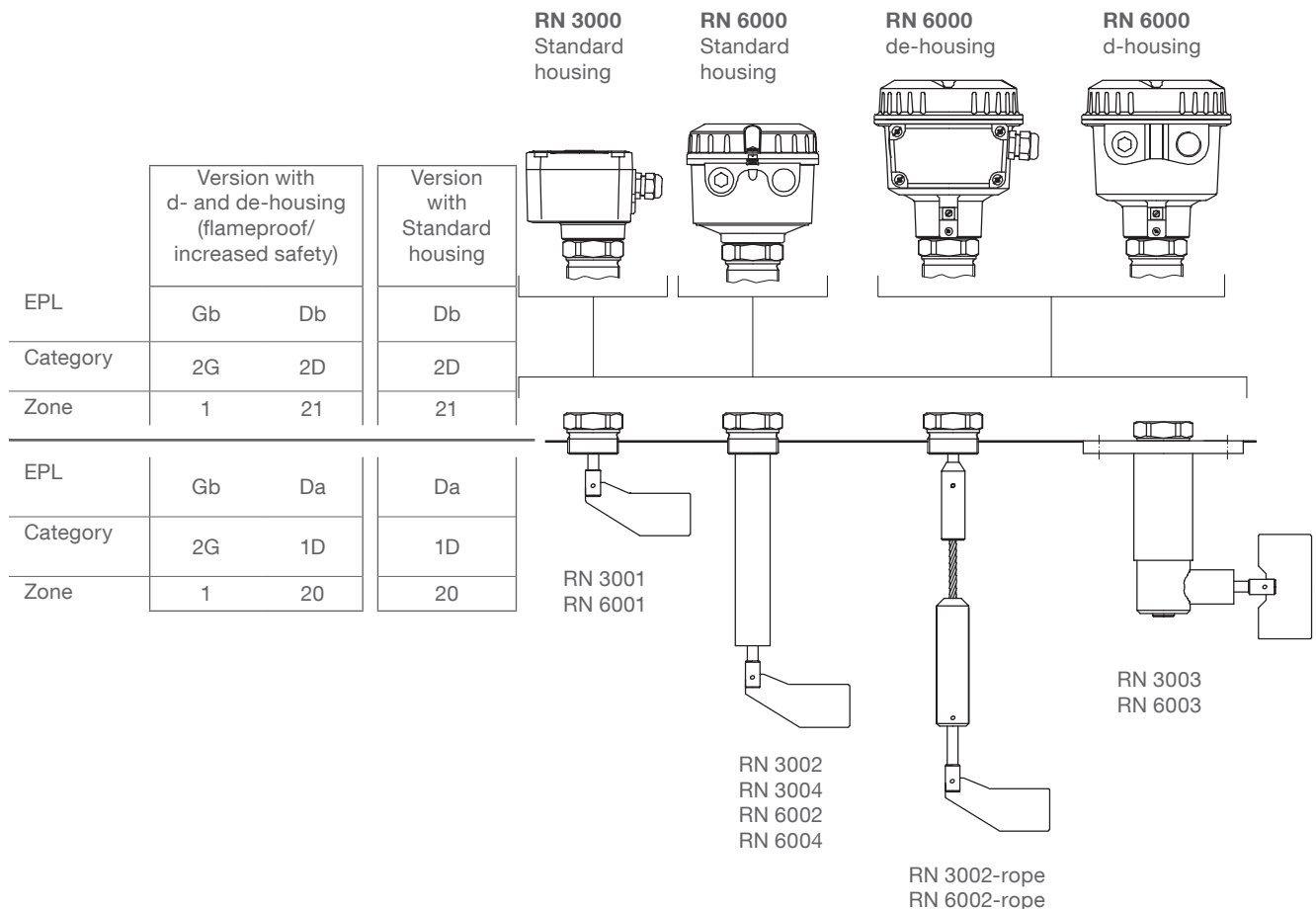

Max. Surface Temperature and Temperature Code

The temperature marking on the name plate  refers to the instruction manual. In the following tables the relevant temperature ratings are shown.

The maximum surface temperature (resp. temperature class) is the warmest temperature of the unit which could occur during malfunction (according to Ex-definition).

Enclosure directly mounted to the process connection					
Max. ambient temperature *	Max. process temperature	Max. surface temperature (EPL Db)	Max. surface temperature (EPL Da)	Temperature class (Division system)	Temperature class (Zone system)
30°C (86°F)	50°C (122°F)	90°C (194°F) 120°C (248°F) ⁽¹⁾	T ₂₀₀ 90°C (194°F) T ₂₀₀ 120°C (248°F) ⁽¹⁾	T5 T4A ⁽¹⁾	T5 T4 ⁽¹⁾
40°C (104°F)	60°C (140°F)	100°C (212°F) 120°C (248°F) ⁽¹⁾	T ₂₀₀ 100°C (212°F) T ₂₀₀ 120°C (248°F) ⁽¹⁾	T5 T4A ⁽¹⁾	T4
50°C (122°F)	70°C (158°F)	110°C (230°F) 120°C (248°F) ⁽¹⁾	T ₂₀₀ 110°C (230°F) T ₂₀₀ 120°C (248°F) ⁽¹⁾	T4A	T4
RN 3000: 60°C (140°F) RN 6000: 50°C (122°F)	80°C (176°F)	120°C (248°F)	T ₂₀₀ 120°C (248°F)	T4A	T4

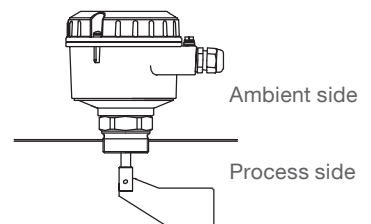

* Ambient temperature derating see page 12

Notes for use in Hazardous Locations / Disposal

Enclosure mounted offset to the process connection					
Max. ambient temperature	Max. process temperature	Max. surface temperature (EPL Db)	Max. surface temperature (EPL Da)	Temperature class (Division system)	Temperature class (Zone system)
RN 3000: 60°C (140°F) RN 6000: 50°C (122°F)	90°C (194°F)	120°C (248°F)	T ₂₀₀ 120°C (248°F)	T4A	T4
	100°C (212°F)	120°C (248°F)	T ₂₀₀ 120°C (248°F)	T4A	T4
	110°C (230°F)	120°C (248°F)	T ₂₀₀ 120°C (248°F)	T4A	T4
	120°C (248°F)	120°C (248°F)	T ₂₀₀ 120°C (248°F)	T4A	T4
	130°C (266°F)	130°C (266°F)	T ₂₀₀ 130°C (266°F)	T4	T4
	140°C (284°F)	140°C (284°F)	T ₂₀₀ 140°C (284°F)	T3C	T3
	150°C (302°F)	150°C (302°F)	T ₂₀₀ 150°C (302°F)	T3C	T3
	160°C (320°F)	160°C (320°F)	T ₂₀₀ 160°C (320°F)	T3C	T3
	170°C (338°F)	170°C (338°F)	T ₂₀₀ 170°C (338°F)	T3A	T3
	180°C (356°F)	180°C (356°F)	T ₂₀₀ 180°C (356°F)	T3A	T3
	190°C (374°F)	190°C (374°F)	T ₂₀₀ 190°C (374°F)	T3	T3
	200°C (392°F)	200°C (392°F)	T ₂₀₀ 200°C (392°F)	T3	T2
	210°C (410°F)	210°C (410°F)	T ₂₀₀ 210°C (410°F)	T2D	T2
	220°C (428°F)	220°C (428°F)	T ₂₀₀ 220°C (428°F)	T2C	T2
	230°C (446°F)	230°C (446°F)	T ₂₀₀ 230°C (446°F)	T2C	T2
	240°C (464°F)	240°C (464°F)	T ₂₀₀ 240°C (464°F)	T2B	T2
	250°C (482°F)	250°C (482°F)	T ₂₀₀ 250°C (482°F)	T2B	T2

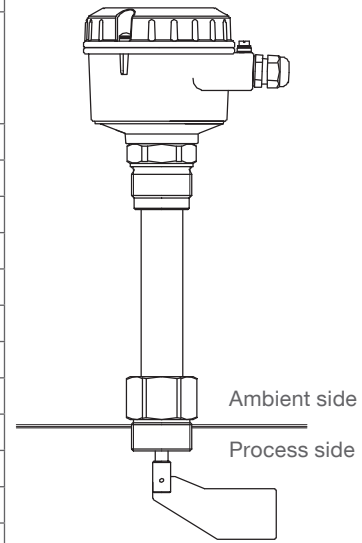

⁽¹⁾ With use of electronic "Universal voltage"

Disposal

The product consists of materials which can be recycled, details of the used materials see chapter "Technical data - mechanical data". Recycling must be done by a specialised recycling company.